

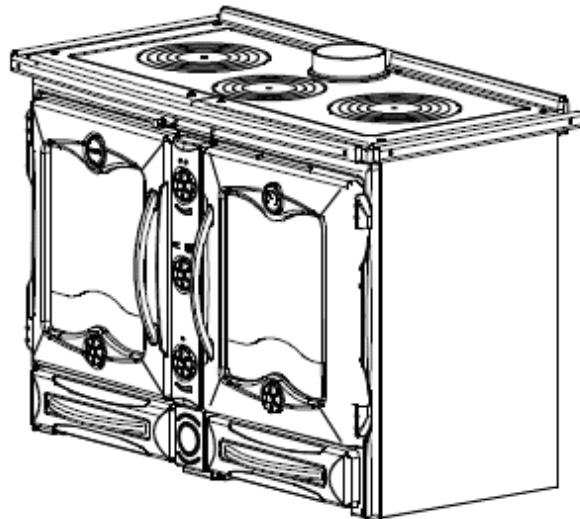

INSTALLATION AND OPERATION INSTRUCTIONS FOR THE:

SUPREMA GRANDE & SUPREMA PETITE

Wood Burning Range Style Cookers

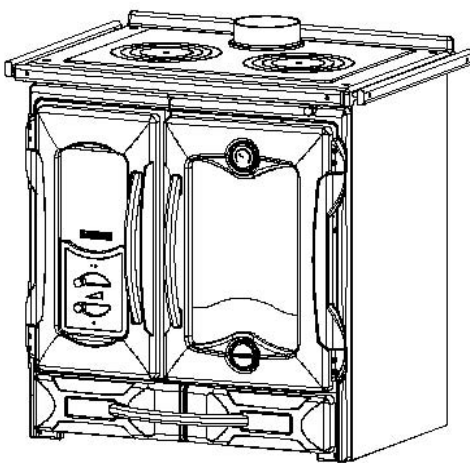

TESTED TO: DIN 180880

This appliance must be installed and commissioned by a fully qualified, registered engineer.

A "Declaration of Completion" Certificate must be obtained for the installation and retained by the end user. Failure to comply with these requirements may void the warranty.

PLEASE READ THESE INSTRUCTIONS THOROUGHLY BEFORE INSTALLING, OPERATING OR SERVICING THIS APPLIANCE.

ISSUE 08-B

INTRODUCTION

Please read the following instructions carefully to get the best from your new purchase.

The keys to safe, successful and efficient wood burning are good planning, correct installation and proper operation.

Modern homes have better levels of insulation and are more energy efficient, with more effective and better seals on doors and windows. This makes our homes easier to heat, but also means that solid fuel appliances must be more carefully designed so that they will function correctly in the energy efficient, modern homes of today. The more energy efficient a house is, the less fuel is required to heat it. Less fuel use means less impact on the environment.

The operation of our appliances, so that they do not produce excessive smoke (beyond the initial light up and reloading periods) is most important. When our appliances are not smoking, it is an indication that it is being operated correctly and efficiently.

The flames that are seen inside the appliance are not the fuel burning, but the carbon particles and gases that are released from the fuel once it has been heated to a sufficiently high temperature. The escape of any unburnt particles and some gases into the atmosphere are the cause of air pollution. Our appliances are designed to ensure that the combustion of all gases and particles takes place within the firebox, to maximize the heat output of the appliance and to minimize the discharge of particulate emissions to the atmosphere.

It is important therefore, for appliances to be operated in accordance with our instructions in a manner that maintains a high temperature in the firebox with an adequate supply of air to ensure efficient combustion. A good indication of efficient combustion is a bright lively flame in the firebox. A dull flame or smoldering fire indicates poor or incomplete combustion.

To maintain adequate heat in the firebox, it is very important to use dry, well seasoned wood with less than 20% moisture content. The wood must be correctly sized for the particular appliance and it also helps to have at least three or four pieces burning at the one time to assist the combustion process.

Adding single pieces of unseasoned or wet wood to a fire will reduce the firebox temperature and prevent adequate combustion. This will result in increased smoke emissions causing the flue and internal components of the appliance to become blocked with tar and creosote more quickly. The tar and creosote deposits in the chimney will fuel a chimney fire.

These instructions cover the basic principles to ensure the satisfactory installation of the stove, although detail may need slight modification to suit particular local site conditions. In all cases the installation must comply with current Building Regulations, Local Authority Byelaws and other specifications or regulations as they affect the installation of the stove.

It should be noted that the Building Regulations requirements may be met by adopting the relevant recommendations given in British Standards BS 8303, BS 6461 and BS 7566 as an alternative means to achieve an equivalent level of performance to that obtained following the guidance given in Approved Document J.

We recommend that you seek the services of an installer who is conversant with stove installations and Building Regulations. The shop where you purchased the stove should be able to help in this respect. It is our general policy to supply specialist Fireplace shops and these shops can offer an after sales service and offer advice when necessary.

Please note that it is a requirement under Broseley Fires Ltd's warranty system that the installation of the appliance is carried out by a Competent Person registered with a Government approved Competent Persons Scheme. HETAS Ltd operate such a Scheme and a listing of their Registered Competent Persons can be found on their website at www.hetas.co.uk.

INDEX

1. TECHNICAL DATA
2. HEATABLE AREA (VOLUME)
3. KEY ENVIRONMENTAL CONSIDERATIONS
4. TECHNICAL DESCRIPTION
- 5 THE 'AIR' CONTROLS
- 5A. THE PRIMARY AIR CONTROL
- 5B. SECONDARY AIR CONTROL
- 5C OVEN/HOTPLATE CONTROL
- 5D LIGHTING BYPASS CONTROL
- 5E OVER-FIRING WARNING
6. USING THE OVEN
- 7 GRILLING
- 8 THE LIFTING GRATE
9. FUEL ADVICE
- 9A. BURNING WOOD
10. INITIAL BURNING & CURING OF THE STOVE
11. USING YOUR STOVE – IMPORTANT NOTES
12. LIGHTING AND MAINTAINING A LOG FIRE
- 13 ASH REMOVAL – CLEANING OUT THE ASH
- 14 WOOD ASH DISPOSAL
- 15 OPERATING IN TRANSITION PERIODS (Summer)
- 16 MAINTENANCE - CLEANING THE APPLIANCE
- 17 A DAILY CARE
- 17 B CLEANING AND MAINTAINING THE APPLIANCE:
- 17 C CAST IRON
- 17 D MAJOLICA TILES
- 17 E ENAMELED SURFACE
- 17 F GLASS CLEANING
- 17 G BROKEN GLASS
- 17 H ASH REMOVAL
- 17 I FLUE MAINTENANCE
- 17 J ROPE SEALS
- 17 K AIR CONTROLS
- 18 SPARES

19. INSTALLATION OF THE APPLIANCE
- 20 FLUE REQUIREMENTS
- 21 LINING THE FLUE
- 22 FLUE TERMINATION
- 23 PROVISION OF A NOTICE PLATE
- 24 SITING THE APPLIANCE
- 25 HEARTH REQUIREMENTS
- 26 STOVE CLEARANCES
- 27 ADDITIONAL VENTILATION
- 28 CHIMNEY FIRE
- 29 ASSEMBLING THE HANDRAILS

ANNUAL SERVICE RECORD
LIMITED WARRANTY

1. TECHNICAL DATA

	<u>SUPREMA GRANDE</u>	<u>SUPREMA PETITE</u>
Nominal Heat Output (kW)	10	8
Flue diameter (MINIMUM) *an adaptor is required	150mm (6 inch)	150mm (6 inch)
Efficiency (%)	76	78
Hourly consumption - wood (kg/h) (To maintain nominal output)	3.1	2.6
Flue draft pressure (Pa) (Tested at nominal output)	12 (1.2 mm water)	12 (1.2 mm water)
Gas emissions in g/s - wood	12.2	8.7
Temperature exhaust gas – wood (°C)	300	310
Firebox opening (mm)	325 x 405	
Firebox area (mm)	400 X 410 X 460	277 X 304 X 460
Oven area (mm)	436 x 418 X 430	307 X 418 X 430
Certification CE	EN 12815	EN 12815
Weight (Kg)	300	200
Height (mm)	880	880
Width (mm)	1280 (inc rails)	880 (inc rails)
Depth	660	664
Grate	Flat	Flat

*** Please refer to the chapter on flue requirements, chapter 21.**

2. HEATABLE AREA (VOLUME)

The heating capacity of rooms according to DIN 18893 for buildings in which the insulation is below the levels recommended in regulations is:

- (30 kcal/m³) - Well insulated:
- (40 kcal/m³) - Average insulation:
- (50 kcal/m³) - Poor insulation:

With adequate insulation the above values will be higher. With temporary use the heating capacity is reduced by around 25%.

3. KEY ENVIRONMENTAL CONSIDERATIONS

To minimize the impact on the environment the following issues need to be considered when proposing to install a solid fuel appliance:

- Local authorities (Councils) must be consulted for any restrictions that may apply to the use of solid fuel appliances in certain areas such as smoke free zones.
- The appliance must be correctly sized to suit the space and necessary clearances must be strictly adhered to.
- The appliance and flue system must be correctly installed to the current regulations in force at the time.
- The appliance must be correctly operated.
- The appliance and flue system must be properly maintained.
- It is also important to ensure that the dwelling to be heated is well insulated and is as energy efficient as is practical before a heating appliance is chosen and installed.
- The correct fuel must be used.

The selection, installation, correct use and maintenance of solid fuel appliances and flue systems are discussed in more detail in the following sections of these instructions.

4. TECHNICAL DESCRIPTION

These appliances allow for cooking on the hotplates on the top of the stove or in the oven. They also provide supplementary heating to the room. The cooker is made from enamelled galvanized steel and enamelled cast iron. The firebox is lined with firebricks of cast iron and ceramic fire bricks and has tertiary combustion for greater efficiency. Inside is a flat cast iron grate that is adjustable in height.

The firebox has a panoramic door with ceramic glass (heat resistant to 700C). This allows a fascinating view of the flames whilst preventing any escape of sparks or smoke. Underneath is a large storage draw for logs.

The heat is provided by radiation through the glass door and from the hot external surfaces of the stove.

Air regulators adjust the combustion rate of the stove.

5 THE 'AIR' CONTROLS

The stove is fitted with four manual air controls that adjust the flow of air into the unit. It is very important that these controls are fully understood in order to achieve the best results from your stove.

When operating the controls, ensure that they are used in small increments and not changed by large amounts suddenly. Do not use them like an on – off switch.

It is also important that the controls are used correctly in order to prevent “over-firing” (See section *OVER-FIRING* warning)

The air controls are as follows:

- PRIMARY AIR CONTROL
- SECONDARY AIR CONTROL (AIR WASH)
- OVEN / HOTPLATE DIVERTER CONTROL
- LIGHTING BYPASS CONTROL

There is also a control that is the riddling grate. Please see below for an explanation.

5 A THE PRIMARY AIR CONTROL (spinner) see FIG.1 A

The primary regulator is found on the centre of the stove towards the bottom and is in the form of a spinner. It has one dot cast above the spinner and a high - low indicator below. With the spinner rotated anticlockwise the regulator is open and with it rotated clockwise in it is closed.

The primary air control is mainly used when lighting and establishing a new fire. This control introduces combustion air from below the grate on which the fuel is laid. Once a fire is well established the primary air control will generally be closed down and the combustion then controlled using the Secondary air control.

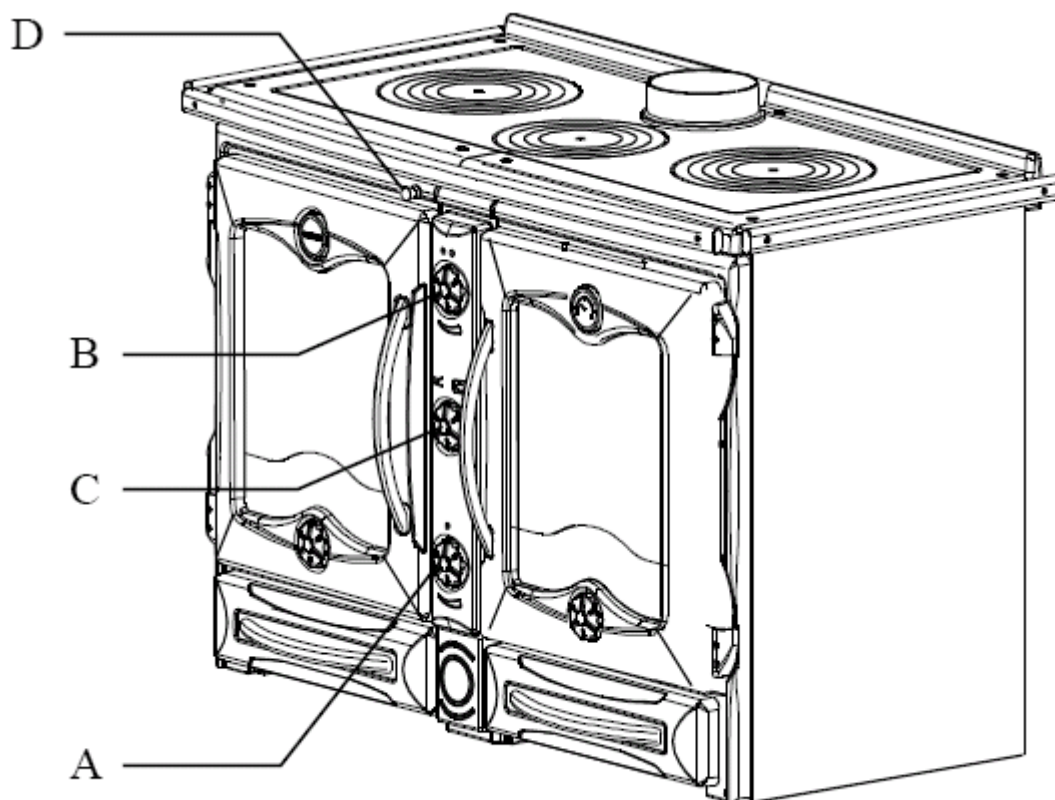

5 B SECONDARY AIR CONTROL (spinner) see FIG 1 B

The secondary air regulator is located in the centre of the stove front towards the top. It has two dots cast above the spinner and a high - low indicator below. With the spinner rotated anticlockwise the regulator is open and with it rotated clockwise in it is closed.

Combustion air entering the stove through this vent will be directed down the inside of the glass panel, this is known as the ‘air wash system’. This helps to keep sooty deposits from sticking to the glass and obscuring the view of the flames. Having clean glass also improves the heat radiation through it.

This control will be used to control the combustion rate once a fire is established.

5 C OVEN / HOTPLATE CONTROL (spinner) see FIG 1 C

On the front of the cooker; midway between the primary and secondary controls; is the control that, when turned to the right, sends the hot gases directly to the hotplate, bypassing the oven. When turned to the left, the hot gases flow around the oven heating it up to allow for cooking.

5 D LIGHTING BYPASS CONTROL see FIG 1 D

Above the fascia of the stove and just below the hotplate is a lever with a chromed handle. This is used only when lighting the cooker. With the lever pushed in the exhaust gases flow directly to the chimney and this facilitates easy lighting. Once the fire is going well and burning cleanly, the lever should be pulled fully out. This diverts the hot gasses around the oven. Diverting the gasses too soon will send tar and cold smoke round the oven and will insulate all the surfaces that make contact with the dirty smoke. **DO NOT** operate the diverter control until the smoke is hot and clean.

5 E OVER-FIRING WARNING

IT IS EXTREMELY IMPORTANT NOT TO LEAVE ALL OF THE AIR CONTROLS FULLY OPEN. LEAVING THE AIR CONTROL FULLY OPEN WILL LEAD TO "OVER-FIRING". OVER-FIRING IS CAUSED WHEN TOO MUCH HEAT IS GENERATED WITHIN THE FIRE CHAMBER, THIS WILL LEAD TO WARPING, BUCKLING AND GENERAL DAMAGE TO THE STOVE AND ITS INTERNAL COMPONENTS. OVER-FIRING CAN ALSO BE CAUSED BY RUNNING THE APPLIANCE WITH THE DOOR(S) OPEN OR IF YOU HAVE AN EXCESSIVE FLUE DRAW. PLEASE NOTE ANY DAMAGE TO THE APPLIANCE CAUSED THROUGH OVER-FIRING WILL NOT BE COVERED BY THE WARRANTY.

6 USING THE OVEN

After having cleaned out the grate, load it with fuel. By adjusting the primary and secondary air controls, according to the type of fuel being used (see paragraph 9), the rate of burn and thus the temperature of the oven can be regulated. The flue draft on the chimney will need to be correct for the fuel to burn efficiently and the appliance achieve the output to which it has been tested. Ensure that the lighting bypass control is fully pulled out and that the oven / hotplate control is turned to the left.

Dishes can be placed on different levels within the oven. Large cakes and roasts are best put on the lowest level, shallow cakes, tarts and biscuits in the middle. The top level is used for reheating or browning.

7 GRILLING

With the 'Suprema Grand' model, it is possible to use the stove for grilling as well. To do this the firebox door must be opened and the external hood put into place (see figure 2). The grill can then be put into the cooker.

The air controls should be set as follows:
Primary and secondary should both be closed, that's turned fully clockwise. The oven/hotplate control should be turned to the right.
The lighting bypass control should be on that is pushed towards the back of the cooker.
To improve the performance when grilling, it is possible to raise the grate. See following paragraph 8.

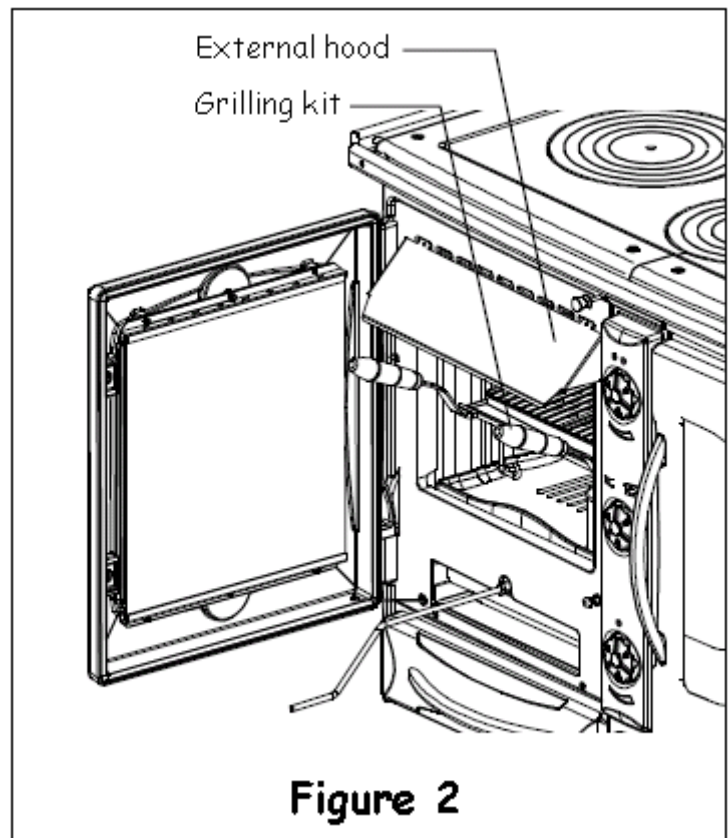

8 THE LIFTING GRATE

The Suprema Grand has a grate that can be raised and lowered by means of a crank. A crank handle is provided and it attaches to the square peg located just above the ash drawer (see figure 3).

Raising the grate is useful when grilling if extra heat is required. Alternatively if you are cooking on the hob only, and have no need to keep the fire going when you have finished, you can lift the grate closer to the hob as the fire diminishes thus allowing you to get the best heat from the fire as it slowly dies.

Ensure that the fire chamber and the crank mechanism are kept clean and well maintained. This will allow you to use this feature to its best. If the grate is restricted in any way it will be almost impossible to move.

To clean the mechanism that cranks the grate, just lift out the grate (when cold) and this will expose the rack and screw. Brush any loose ash from the top of the rack and crank the unit up and down, without the grate in place, to ensure that the screw is free. Check that there is no soot or other deposits on the inside of the firebox that could impede the travel of the grate.

Before replacing the grate ensure that all the accumulated ash in both the ash pan and the ash drawer is completely removed. Failure to clean the ash drawer properly can lead to problems positioning the ash pan and then cause problems with door closure.

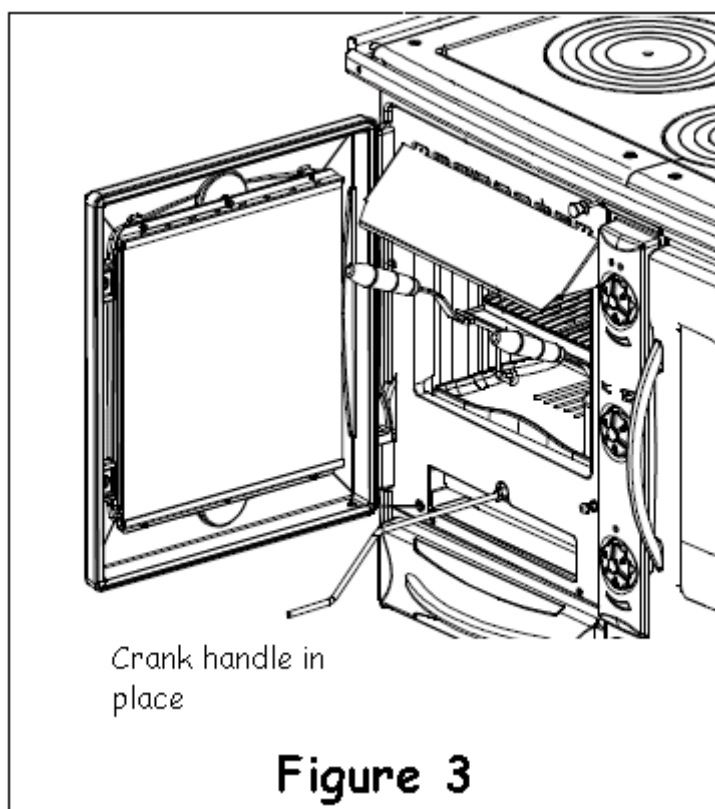

9 FUEL ADVICE

The appliance has been designed to burn wood as its primary fuel source.

You need to use good quality fuel in order to get the best results from your stove. Seek advice from your local fuel merchant as he will be able to advise you on what wood are best to use.

All outputs stated in our literature are based on test firings carried out using beech logs with a moisture content of less than 20%. Too much fuel and too much air can cause overheating and so damage the stove.

Damage caused by overheating is not covered by the guarantee. You should, therefore, always use the stove with the door closed to avoid this.

9 A BURNING WOOD

Most firewood will contain a large amount of water and will therefore need to be stored in a well ventilated shelter to season it. Wood used in this appliance must have a moisture content of less than 20%. Damp or wet wood will quickly form tar deposits on all the internal areas where the combustible gasses travel, preventing the efficient release of heat from the appliance. The inside of the chimney/flue will also be coated, there is a greater risk of a chimney fire occurring.

When selecting wood, also take into consideration ease of splitting, ease of ignition and burning, how much smoke it produces and its "coaling" qualities. "Coaling" refers to the ability of a species of wood to form a long- lasting bed of hot coals when burned. Coaling qualities improve with wood of a higher density. Wood is not a long burning fuel and so it is not always possible to keep the stove in overnight.

10 INITIAL BURNING AND CURING OF THE APPLIANCE

The first time that the appliance is lit, there will be an odour given off. This is the components of the appliance curing. It will be necessary to ventilate the room in which the appliance is sited.

The first firing needs to be done carefully to allow all of the components of the appliance to settle gradually. Never try to run the appliance flat out the first time you light it. It will be necessary to keep the fire burning for longer periods rather than short periods the first four to five times. This will be the best way to achieve correct settling of the appliance. Do not burn the appliance at an accelerated rate; a steady burn is all that is required.

Gradually build up the output of the fire so that no sudden stresses are put on the components of the appliance.

During the first lightings, nothing should be leant against the stove and in particular on the varnished surfaces. The varnished surfaces must not be touched during the initial curing process.

11. USING YOUR STOVE - IMPORTANT NOTES:

This appliance must be installed and commissioned by a fully qualified, registered engineer. HETAS engineers are recommended by Broseley Fires. For your nearest search www.hetas.co.uk

THE SURFACES OF THIS APPLIANCE GET HOT WHEN IN USE. PLEASE ENSURE THAT CHILDREN, THE ELDERLY AND THE INFIRM ARE MADE AWARE OF THIS. DO NOT HANG COMBUSTIBLE ITEMS FROM THE RAILS.

- Serious damage can result if the appliance is left running with the air controls fully open for extended periods.
- Make sure that none of the doors are left open while the appliance is in operation.
- Never leave the appliance unattended during the initial lighting sequence.
- Do not attempt to open the door immediately after igniting the fire. This could cause a flame flash out.
- Always wear the protective gloves when operating the appliance.
- Never burn wood which contains any form of paint or other chemicals.
- Do not overload the appliance with fuel.
- Never use chemicals or fluids such as gasoline, charcoal lighter, drain oil or kerosene to light a fire.
- Using the appliance on a very low output will cause excessive amounts of tar to build up inside the flue and can be a serious fire risk, as this will fuel a chimney fire. You will need to have the flue cleaned and serviced more regularly.
- Never overload the stove (consult the technical table- maximum allowable quantities)
- We advise that you have the appliance serviced annually by a competent heating engineer before the beginning of a new heating season.
- Do not cover the permanent air vent that your heating engineer has installed; this is necessary for the correct combustion of the appliance and your safety.
- On boiler appliances, don't light the fire if there is a risk that any part of the system is frozen.

Make sure that children the elderly and the infirm are aware of these dangers and keep them away from the stove while it is in use.

12 LIGHTING AND MAINTAINING A LOG FIRE

All chimneys and flues act differently. After a while, you will find out how your unit works best for starting. Ensure that the draft measurement is correct at the time of installation.

- Use scrunched up paper and dry kindling to start the fire. Lay these on the grate. An alternative is to use fire lighters.
- Open the primary and secondary air controls to the fully open position. It will take a short time for the fire to establish itself.
- When the fire is burning hot, add small pieces of very dry wood, preferably hardwood as these generate better embers.
- Keep all the draft controls fully open till a bed of hot, glowing embers is established.
- Once you have some red hot burning embers, open the door and rake the embers evenly over the grate before adding larger pieces of wood.
- We suggest that you do not fully load the appliance until you have become completely familiar with the operation of ALL the controls.
- For best results, in an ideal situation, keep the secondary air control open and close the primary air control. The output of the appliance can now be controlled using the secondary air control.
- Do not open the loading door too quickly when reloading the appliance as this can cause flames to flash out the door. This occurs when there is unburned fuel and a large amount of gases in the top of the firebox. When the door is opened, oxygen is combined with the gases and these ignite, causing a 'mini explosion'.
- A typical load will be 2 KG; this will maintain the output of this appliance
- Do not burn painted or varnished woods, MDF, oak bark or any wood with more than 20% humidity.
- It is not necessary to release the ash using the 'riddling grate' as wood burns best on a flat surface.

13 ASH REMOVAL – CLEANING OUT THE ASH

The removal of the ashes should be done when the appliance is cold.

Ash must be removed periodically for the correct and efficient operation of your appliance.

Don't wait till the ash pan's completely full. The frequency of this ash removal will depend on the wood being burned, as. Softwoods and hardwoods generate differing amounts of ash.

Keep in mind that cleaning your appliance boosts its efficiency, as ash, soot or tar deposits will block the heat from coming out of the appliance. Excess ash in the pan can potentially cause the fire to go out and may cause severe damage to the grate. It may also prevent the ash door from being shut correctly. Periodical inspection of the ash chamber is recommended. Take care when removing the ash, as small bits of hot embers can stay dormant for long periods when buried in ashes. These will then flare up again when exposed to oxygen; some knowledge of proper ash removal is required for safety. Here are the important points: Remove ashes to a metal container using a small trowel. Never vacuum the ashes unless it is a genuine 'Ash Vac'. This is a vacuum you can buy at hearth shops; it is specifically designed for ash removal. Place the filled ash bucket on a non-combustible surface such as stone, concrete, brick, or slate, as the heat will transfer through the bottom of the container. Fit a lid for extra safety. For your own protection, a pair of heat proof gloves and a dust mask may be necessary.

14 WOOD ASH DISPOSAL

The best thing to do with your ashes is to put them in your garden. Wood ashes are high in potassium, calcium, sodium, magnesium, and phosphorus. Wood ash will make your soil more alkaline, so apply it appropriately for your soil. In areas where of high rainfall, this is a benefit because the soils there are typically acidic.

Dry areas tend to have more alkaline soil, so adding wood ash might be a problem.

If you have no garden, you can dispose of completely cold ash with your household trash.

Place it in a tightly closed bag to keep it contained.

15 OPERATING IN TRANSITION PERIODS (Summer)

When the outside temperature gets to be more than the temperature within the property, there is a strong possibility of the flue working in reverse. If the appliance is not lit, this will cause the draught of the flue to travel in a downward direction and the smell of smoke will be obvious in the room.

If you experience problems lighting the appliance because of the greater outside temperature, then it will be necessary to warm the flue before loading the appliance with kindling. There are various methods for this procedure.

Ask your local supplier or registered chimney sweep for advice.

If the fire is lit, the heat output of the appliance is often reduced and the exhaust gases may not come out the chimney completely. This can cause them to come back into the room.

In this case,

- shake the embers more frequently,
- increase the air for combustion and
- only load a reduced quantity of fuel.

This will help to keep the chimney hot and working efficiently.

Check that all the seals of the appliance are in good order and that the connections to the chimney are also sound.

16 MAINTENANCE - CLEANING THE APPLIANCE

Take great care choosing the products you use to clean your appliance. A major amount of cleaning can be carried out using hot soapy water and a soft cloth. Using the wrong products will cause damage to its surfaces. Never use bleach or chlorine based products, caustic cleaners, paint solvents, biological powders, coarse abrasives or salt. Never mix different products as they may cause a chemical reaction with each other and cause harm to either you or the appliance. Read below to see specific cleaning techniques. For the more stubborn stains, a mildly abrasive cleaner should be used, such as 'Astonish. This is safe to use on enamel surfaces. Do not use Astonish on the chrome components. *For any further information, please contact your Dealer!*

17 A DAILY CARE

To keep the surfaces of your appliance bright and clean, a daily wipe over with a lint free cloth is all that is needed. A wet cloth may be used on certain surfaces. To buff the cleaned surfaces, a soft, dry, lint free cloth should be used. In order to keep your appliance in tip top condition, it is necessary to wipe up any spills or condensation streaks as soon as is safe to do so. (i.e. when the unit is cold) This will prevent the mark burning onto the appliance and becoming a much tougher stain to remove at a later date, or causing a permanent mark. Try not to use excessive amounts of water when cleaning the appliance.

17 B CLEANING AND MAINTAINING THE APPLIANCE

The appliances have three main surface finishes; these should be cleaned when the appliance is cool. Please follow any instructions to the letter for any special cleaning agent that you may use. Ash removal and chimney maintenance are also important areas to be aware of to ensure the efficient and correct operation of your appliance. Please read on....

17 C CAST IRON

This can be cleaned with a lint free damp cloth. Do not leave this surface wet as it will go rusty. If it is cleaned when the appliance is slightly warm, the damp surface will dry by itself. Otherwise, wipe the surface dry after cleaning. Another method is to brush the surface with a soft brush. This is good for cleaning in the more detailed and difficult to get to areas. If cast iron is left for long periods in a damp atmosphere; such as a fireplace; it may start to show signs of rust. To prevent this, wipe the surface over with light oil. This will burn off when the fire is re-lit.

17 E ENAMELED SURFACE

These can also be cleaned with lint free damp cloth and then wiped over with a dry cloth.

17 F GLASS CLEANING:

Only clean the glass when the appliance is cold. There are various glass cleaners you can buy at stove shops that are specially designed to remove hydrocarbon (soot) and fly ash (mineral) deposits from the glass. Follow the manufacturer's instructions. Typically, just spray a small amount of cleaner on the glass and use a paper towel or rag to wipe it clean. Alternatively use a proprietary ceramic hob cleaner such as Hob-brite, as used for ceramic hobs. Follow the directions on the product. The directions for use on the bottle are to turn the appliance off, apply cleaner with paper towel or clean cloth, rub the glass lightly, rinse residue and dry the glass with a paper towel/soft clean tissue.

If you only burn logs in your appliance, then you can dip a damp cloth in the ash and use this to scrub the glass clean.

17 G BROKEN GLASS

The glass in the fire door is ceramic and is resistant to sudden temperature changes up to 700 degrees Centigrade. Breakage can only be caused by mechanical shock (collision, violent damage etc) because of this; replacement is not covered by the guarantee.

17 H ASH REMOVAL:

The efficient operation of your appliance is dependant on its correct installation, operation and maintenance. Leaving soot to accumulate inside your appliance will drastically reduce the output of the appliance and prevent it from doing what it is designed to. Ensure that the ash inside every part of the appliance is removed, not just the ash pan. Ash will settle on top of the baffle and this is an area that will also need periodic inspection.

17 I FLUE MAINTENANCE:

Call a certified chimney sweep (National Association of Chimney Sweeps) or other qualified professional to clean the flue system. These professionals have the equipment and the experience to do a thorough job. The sweep will advise you as to the intervals that you should have your flue swept. We would recommend that you have it swept at least twice a year, but you may need to sweep it more.

Get them to inspect the condition of all the associated chimney items and report to you on their condition. Be sure to check the pipe at least once every six months to determine if it has corroded.

17 J ROPE SEALS:

For the appliance to operate correctly, it is important that all the seals; where fitted; are in good condition and are sealing correctly. They should be replaced if they are showing excessive signs of fraying and are not making a good seal. They are glued into position using a high temperature, flexible, silicone sealant

17 K AIR CONTROLS:

Ensure that all the air controls operate smoothly and are free from ash or other foreign bodies. Pay particular attention to the damper flap at the rear of the ash drawer. Clean this area with care and ensure that excessive amounts of ash are kept from building up and affecting the operation of this control.

18 SPARES

THE APPARATUS MUST NOT BE MODIFIED. ONLY SPARE PARTS EXPRESSLY AUTHORISED AND SOLD BY BROSELEY FIRES LTD. CONSULT YOUR LOCAL AUTHORISED DEALER FOR ADVICE.

There is a sectional view of the appliance that shows the internal components of the appliance;

See chapter 29. INTERNAL BAFFLE POSITIONS FIG. 6 at the end of this instruction manual. There are also technical drawings of the appliances.

19. INSTALLATION OF THE APPLIANCE

THIS APPLIANCE MUST BE INSTALLED AND COMMISSIONED BY A FULLY QUALIFIED, REGISTERED ENGINEER.

The guarantee is void if any part of the installation is found to be illegal.

- This appliance must be installed into a '**Class 1 Chimney**'. If there is no existing chimney, then an approved solid fuel, factory built, prefabricated block type or a twin walled, stainless steel flue can be used. Get advice from a qualified chimney engineer. Flue sharing is not allowed.
- The flue diameter of these appliances must be a minimum of 150mm diameter.
- If excessive draw is present, then a suitable 'flue draught stabilizer' should be fitted.
- If the chimney suffers from down draught, then a special 'anti-downdraught' cowl will need to be fitted. In exposed windy locations, a 'stabilizing' cowl may need to be fitted. The minimum cowl requirement that we recommend, is a rain cowl with a bird guard.
- To perform satisfactorily, the chimney height must not be less than 5 meters from stove to cowl. If there are any bends in the flue, this minimum length will need to be increased by 1 meter for each bend.
- The initial connection to the appliance will need to be 600mm vertical before any bend.
- A soot door will be required to facilitate the sweeping of the flue.
- A maximum of four 45 degree bends is allowed in any complete flue; from stove to cowl.
- Adequate access for sweeping the flue, such as a soot door, must be provided.
- Flue pipe should be fitted inside the flue pipe collar (spigot) to prevent creosote and condensates from running down onto the top of the appliance. (see specifications for exact collar sizes)
- All flue pipe must be suitable for solid fuel (complies with latest European regs.) and fitted in accordance with building regulations, whilst complying with current legislation and manufacturers' instructions.
- If a rear flue is able to be fitted, the horizontal length must be no longer than 150mm.
- If there is additional ventilation in any room, this will create air depression and the risk of the products of combustion being drawn into the room Mechanical ventilation in the same room as any solid fuel appliance must be avoided.
- This appliance should be connected to an open vented system in line with building regulations and any other regulations that are in force at the time should be observed.

20 FLUE REQUIREMENTS

This appliance has a European sized flue collar that is metric in size. An adaptor is required for the initial connection to the flue collar. (spigot) This is available from your stockist.

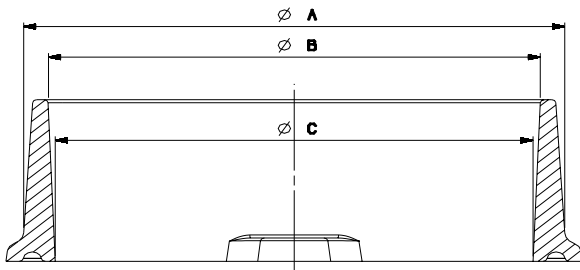

SUPREMA GRANDE

ø A = 160 mm

ø B = 151 mm

ø C = 148 mm

SUPREMA PETITE

ø A = 150 mm

ø B = 141 mm

ø C = 138 mm

BOTH appliances requires a minimum flue diameter of 150mm

The draw of the chimney should be at least 12 Pa (1.2mm of a column of water). The measurement must always be done when the stove is hot (producing nominal heat values). When the pressure exceeds 17 Pa (1.7mm of a column of water) it will be necessary to control it by the installation of a flue draught stabilizer.

Installation, construction, and maintenance of chimneys and flues must comply with Building regulations 'Approved Document (ADJ)' A guidance document is available to assist in the interpretation of the Approved Document.

Any domestic solid fuel appliance will only work efficiently when connected to a chimney system capable of generating adequate up-draft to induce sufficient air supply for complete combustion and to overcome any friction resistance association with the system. The natural up-draft on a chimney will depend on a number of factors. The chimney is one of the most important parts of the installation; great care should be given to its design.

The chimney must be thoroughly swept, checked for soundness and suitability, before any connection is made to the appliance. This must be carried out by a qualified person. If re-using an existing flue, the flue and the chimney should be checked and if necessary, altered to ensure that they satisfy the requirements for the proposed use. Lining a defective flue is an option.

21 LINING THE FLUE

An independently certified flexible metal liner can be used to reline a chimney. An insulated chimney is the most efficient and safe way to burn wood.

An insulated chimney helps prevent tar deposits forming. A standard chimney will gradually get saturated in tar, this is a fire hazard. Tar stains may appear on the surface of the chimney breast inside the property.

22 FLUE TERMINATION

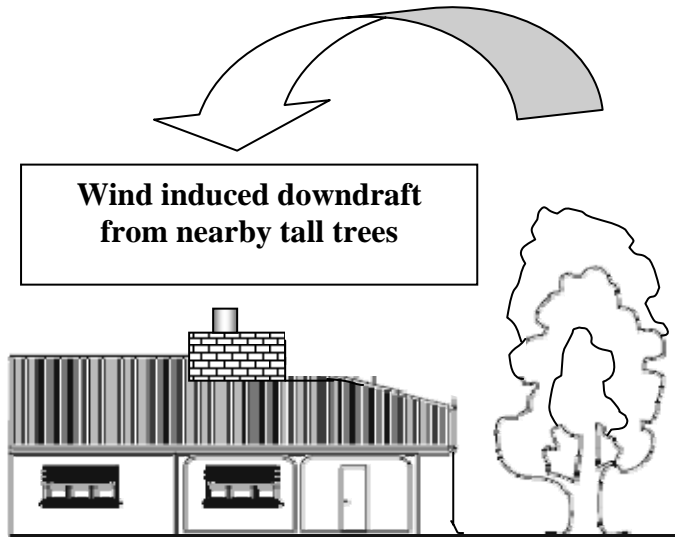

The height and termination of the flue is an important part of the installation and consideration needs to be made to ensure that the flue is high enough to create sufficient draft to clear the products of combustion. The termination of the flue outlet position which can meet the requirements in common circumstances are shown in Document J. If there are unusual circumstances that will affect the efficient and safe removal of the products of combustion; the height and/or the separation distances shown in Document J may need to be increased. A special cowl may need to be fitted.

23 PROVISION OF A NOTICE PLATE

A notice plate must be durable and be fixed on site, where a hearth, fireplace flue or chimney is provided or extended (including cases where a flue is provided as part of refurbishment work). ADJ states that the responsibility for achieving compliance with the requirements of Part J rests with the person carrying out the work and so this person must be competent in the work they are being asked to do. The completed flue must pass the appropriate tests that assess whether the flue in the chimney, the connecting flue pipe (and flue gas passages in the appliance) are free of obstruction and acceptably gas tight. In addition, appliance performance tests, including flue spillage tests should be carried out when an appliance is commissioned.

24 SITING THE APPLIANCE

This appliance must not be fitted into a location where it will be impossible to service. The location must comply with the requirements laid down in the Building Regulations.

25 HEARTH REQUIREMENTS

It is essential that the hearth / base on which the appliance will stand is strong enough to support the weight of the appliance and the chimney / flue. In certain circumstances, it may be necessary to support the flue pipe with brackets. The hearth must be level and made of a suitably robust, non combustible material.

The positioning of the appliance and dimensions of the hearth must comply with current building regulations. Manufacturer's instructions relating to clearances must be adhered to.

26 STOVE CLEARANCES

STOVE CLEARANCES TO FLAMMABLE MATERIALS (SEE FIG. 4A below)

- The minimum distance from any flammable object, or one that is sensitive to heat, (furniture, wood, fabrics. etc.) and from materials with flammable structure, must be 200 mm to the rear and 200 mm both sides.
- In front of the appliance there must be no flammable object or material, sensitive to heat within 1000mm.
- Above the appliance, there must not be any flammable items within 700mm.

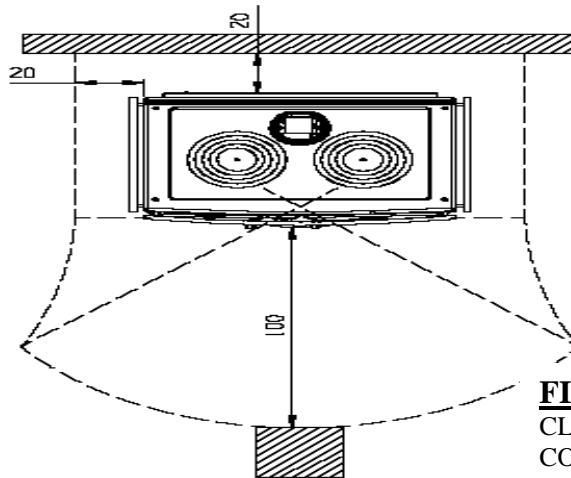

FIG. 4A
CLEARANCE TO
COMBUSTIBLE SURFACES

STOVE CLEARANCES TO NON FLAMMABLE MATERIALS

- The minimum distance from any NON FLAMMABLE object, or one that is NOT sensitive to heat, (stone brick slate etc.) and from materials with non flammable structure, must be 100 mm to the rear and both sides.

Where the hearth abuts a wall and the appliance is more than 50mm but not more than 300mm away;

- The thickness of the wall needs to be at least 75mm
- The height of the wall needs to be at least 1.2m above the hearth.

PLEASE REFER TO BUILDING REGULATIONS "WALLS ADJACENT TO HEARTHES" for further information on this subject.

STOVE CLEARANCES TO NON - FLAMMABLE MATERIALS (SEE FIG. 4 B)

- The minimum distance from any NON FLAMMABLE object, or one that is NOT sensitive to heat, (stone brick slate etc.) and from materials with non flammable structure, must be 100 mm to the rear and both sides.

PLEASE REFER TO BUILDING REGULATIONS "WALLS ADJACENT TO HEARTHES" for further information.

Where the hearth abuts a wall and the appliance is more than 50mm but not more than 300mm away;

- The thickness of the wall needs to be at least 75mm
- The height of the wall needs to be at least 1.2m above the hearth.

27 ADDITIONAL VENTILATION

There must be sufficient free air for combustion into the room where the appliance of 5 Kw or more is installed. THIS IS A LEGAL REQUIREMENT.

Permanent openings or vents must not be covered. Vents needs to be positioned carefully, they must be protected from direct wind conditions. A baffle that has been specially designed to fit over the vent will protect it from the effects of wind, but must not restrict the total vent area and must be secured in a way that prevents its movement. Regular inspection of any vents is critical to ensure that the vent has not become restricted.

The appliance may require up to 20 m³/hour of combustion air. The natural recirculation of air must be guaranteed by having permanent ventilation to the outside.

An extractor fan, cooker hood or similar product, installed in the same room, or in a room nearby; that sucks air out (aspirating); may negatively affect the functions of your appliance.

If the room contains more than one appliance; of the type that requires combustible air; a calculation will need to be made to re-calculate the permanent air vent requirement.

Please see the 'Technical Data' list at the front of these instructions or refer to current building regulations for fixed additional ventilation requirements.

28 CHIMNEY FIRE

If a chimney fire occurs in the flue or the chimney:

1. Immediately shut off the air supply by closing all dampers and air openings on the stove.
2. Ensure the main door and ash door are securely closed.
3. If the fire in the stove or fireplace can be extinguished safely; with a CO2 extinguisher; put it out as quickly and safely as possible. Do not attempt to put out the fire using water.
4. Close all windows and doors to the room.
5. **Call the fire brigade**

When the chimney has stopped burning have it checked by a specialist for possible cracks or leaks. Please review the way you are using the appliance and check that the fuel you are using is suitable. Chimney fires only occur if the appliance has been wrongly installed, maintained or operated. Damage caused to an appliance where a chimney fire has occurred is not covered by any guarantee.

- Please comply with the technical data given in this instruction manual.
- Illegal installations are not covered by any sort of guarantee.

29 ASSEMBLING THE HANDRAILS

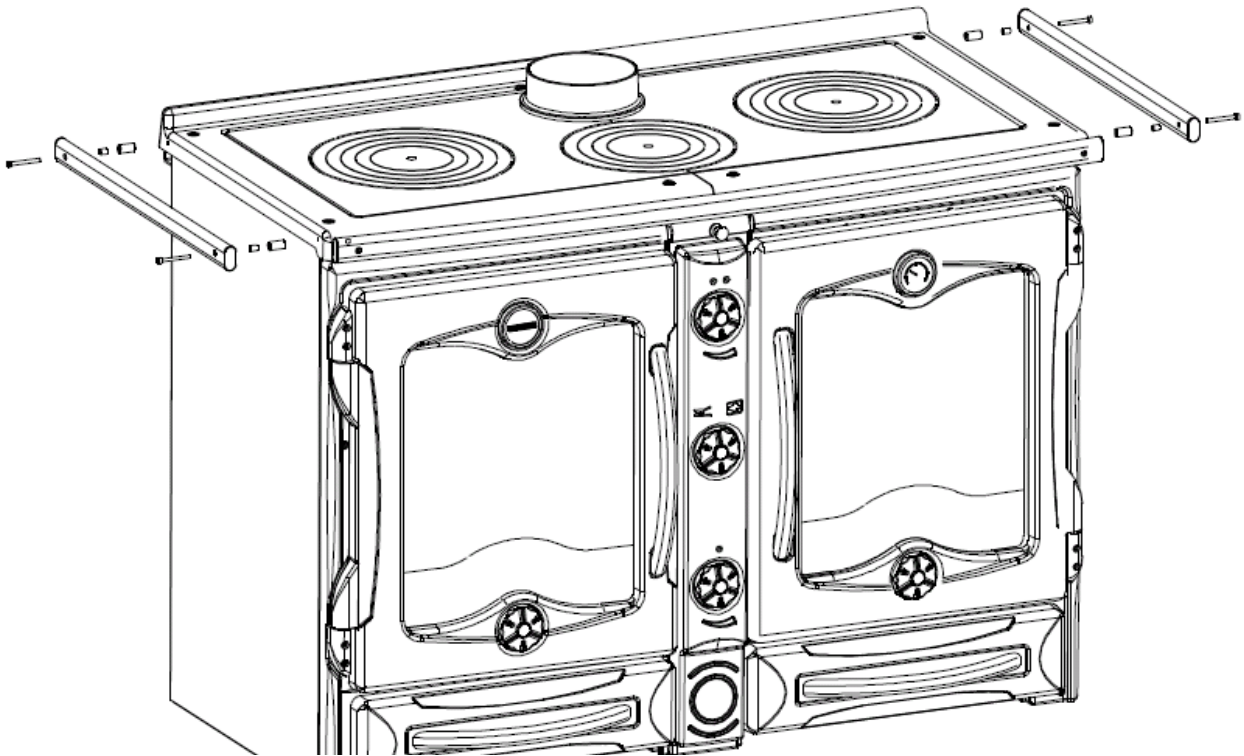

ANNUAL SERVICE RECORD

A "Declaration of Completion" Certificate must be obtained for the installation and retained by the end user. Failure to comply with these requirements may void the warranty.

INSTALLATION DATE OF APPLIANCE: _____

HETAS ENGINEER: _____ . REG. No. _____

COMPANY NAME: _____ .

COMPANY ADDRESS: _____ .

_____ .

POSTCODE: _____

CONTACT NUMBER _____

1ST YEAR SERVICE completion date: _____

HETAS ENGINEER: _____ . REG. No. _____

COMPANY NAME: _____ .

COMPANY ADDRESS: _____ .

_____ .

POSTCODE: _____

CONTACT NUMBER _____

2ND YEAR SERVICE completion date: _____

SERVICE ENGINEER: _____ . . REG. No. _____

COMPANY NAME: _____ .

COMPANY ADDRESS: _____ .

_____ .

POSTCODE: _____

3RD YEAR SERVICE completion date: _____

SERVICE ENGINEER: _____ . . REG. No. _____

COMPANY NAME: _____ .

COMPANY ADDRESS: _____ .

_____ .

POSTCODE: _____

4TH YEAR SERVICE completion date: _____

SERVICE ENGINEER: _____ . . REG. No. _____

COMPANY NAME: _____ .

COMPANY ADDRESS: _____ .

_____ .

POSTCODE: _____

5TH YEAR SERVICE completion date: _____

SERVICE ENGINEER: _____ . . REG. No. _____

COMPANY NAME: _____ .

COMPANY ADDRESS: _____ .

_____ .

POSTCODE: _____

6TH YEAR SERVICE completion date: _____

SERVICE ENGINEER: _____ . . REG. No. _____

COMPANY NAME: _____ .

COMPANY ADDRESS: _____ .

_____ .

POSTCODE: _____

LIMITED WARRANTY

This appliance must be installed and commissioned by a fully qualified, registered engineer. A "Declaration of completion Certificate" must be obtained for the installation and retained by the end user. Failure to comply with these requirements may void your warranty.

You, as the end user, have a contract by law with the supplier / dealer from whom you purchased the product. That dealer then has the same contract with the manufacturer or wholesaler and these have a contract with their suppliers.

ALL CLAIMS MUST FOLLOW THIS PROCEDURE.

Thank you for choosing a Product from **Broseley Fires Ltd**. This warranty gives you specific legal rights. The statutory rights of the consumer are not affected by the warranty, or the consumers' rights against the dealer arising from their sales / purchase contract.

The manufacturers' warranty:

Your Product will be free from defective parts, material, and workmanship at the time of its original purchase for a period of one (1) year. This Warranty will become active as of one month from the date of delivery.

This warranty does not cover any failure of the unit due to normal wear and tear, misuse, abuse, accident, illegal modification, illegal installation or repair, damage resulting from improper use or failure to maintain the product. Variations in color and texture are a natural characteristic of cast iron products. Colour changes may result from exposure to light and other elements which are a part of the aging process. These material variations and changes are not covered by this warranty.

If during the warranty period, this Product fails to operate under normal use and service, due to defects in material and / or workmanship, Broseley Fires will either repair or replace the product. The repaired or replaced product shall be warranted for the remaining period of the original warranty + the time taken to days from the date of repair, whichever is longer.

Repair or replacement may involve the use of functionally equivalent reconditioned units. Replaced parts or components will become the property of Broseley Fires.

Should you wish to claim under the warranty, please contact the supplier / dealer from whom you purchased the appliance. Do not claim directly to Broseley Fires, as they are unable to process any direct claim from an end user.

Product design and any specifications are subject to change without notice. This is due to our continuous product development and improvement. The buyer will not be entitled to request free upgrades to the new design or compensation for previously purchased products or any products on order.

- This Warranty covers all Broseley Fires costs within the Warranty period.

If the appliance remains uninstalled for a period greater than six months from date of delivery the Warranty will become active six months from the date of original invoice to the distributor.

IN NO EVENT SHALL BROSELEY FIRES BE LIABLE FOR INCIDENTAL OR CONCEQUENTIAL DAMAGES OF ANY NATURE WHATSOEVER, INCLUDING BUT NOT LIMITED TO LOST PROFITS OR COMMERCIAL LOSS, TO THE FULL EXTENT THOSE DAMAGES CAN BE DISCLAIMED BY LAW. (if applicable)

NON - COVERAGE OF THE GUARANTEE

The consumable items within the product are not covered by the warranty, nor is the glass

If the end-user's claim should not be covered by this guarantee, the end-user shall be liable for costs incurred by Broseley Fires such as callout and inspection costs for examination of the product, transportation costs of the product as well as any other relevant costs.

If, after having been informed about the non-coverage of the guarantee, the end-user wants to have the repairs done, the end-user shall additionally pay for any spare parts used and for the labour and transportation costs incurred. If repairs are carried out under this guarantee, the remaining guarantee period for the product shall be extended by the period of time that has elapsed since the complaint was officially logged with Broseley Fires until the repairs have been completed

A COPY OF OUR FULL TERMS AND CONDITIONS IS AVAILABLE ON REQUEST.

** End-user means the natural or legal person who owns the product and who has not acquired it with a view to reselling or installing it in the course of business