

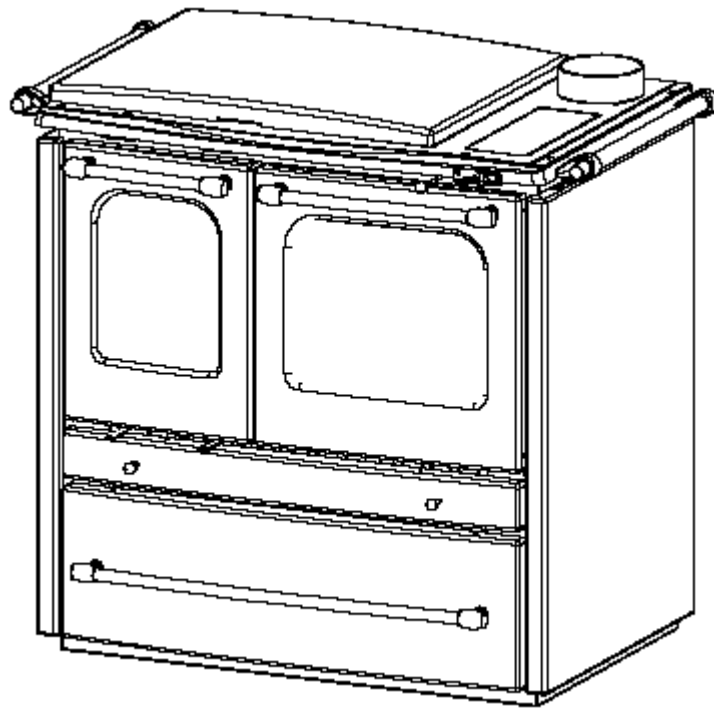

INSTALLATION AND OPERATION INSTRUCTIONS FOR:



THERMO SOVRANA & SOVRANA

THE BOILER AND NON BOILER VERSIONS



TESTED TO EN 12815: 2001 +A1: 2004

This appliance must be installed and commissioned by a fully qualified, registered engineer.

A "Declaration of Completion" Certificate must be obtained for the installation and retained by the end user. Failure to comply with these requirements may void the warranty.

PLEASE READ THESE INSTRUCTIONS THOROUGHLY BEFORE INSTALLING, OPERATING OR SERVICING THIS APPLIANCE.

Revision: 08-C

INTRODUCTION

Congratulations on buying a product distributed by Broseley Fires Ltd.

The keys to safe, successful and efficient wood burning are good planning, correct installation; by a qualified heating engineer; and proper operation.

INDEX

1. TECHNICAL DATA
2. HEATABLE AREA (VOLUME)
3. KEY ENVIRONMENTAL CONSIDERATIONS
4. TECHNICAL DESCRIPTION
- 5 THE 'AIR' CONTROLS
- 5A. THE PRIMARY AIR CONTROL
- 5B. SECONDARY AIR CONTROL
- 5C AUTOMATIC THERMOSTAT CONTROL
- 5D OVER-FIRING WARNING
- 6 ADVICE ON DIVERTING THE HOT FLUE GASSES.
- 7 FUEL OPTIONS
- 8 BURNING WOOD
- 9 INITIAL BURNING & CURING OF THE STOVE
- 10 USING YOUR STOVE – IMPORTANT NOTES
- 11 LIGHTING AND MAINTAINING A LOG FIRE
- 12 ASH REMOVAL – CLEANING OUT THE ASH
- 13 ASH DISPOSAL
- 14 OPERATING IN TRANSITION PERIODS (Summer)
- 15 MAINTENANCE - CLEANING THE APPLIANCE
- 15 A DAILY CARE
- 15 B CLEANING AND MAINTAINING THE APPLIANCE:
- 15 C CAST IRON
- 15 D ENAMELED SURFACE
- 15 E GLASS CLEANING
- 15 F ASH REMOVAL
- 15 G FLUE MAINTENANCE
- 15 H ROPE SEALS
- 15 I AIR CONTROLS
- 15 J CLEANING
- 16 SPARES

17. INSTALLATION OF THE APPLIANCE

- 18 FLUE REQUIREMENTS
- 19 LINING THE FLUE
- 20 FLUE TERMINATION
- 21 PROVISION OF A NOTICE PLATE
- 22 SITING THE APPLIANCE
- 23 HEARTH REQUIREMENTS
- 24 STOVE CLEARANCES
- 25 ADDITIONAL VENTILATION
- 26 CHIMNEY FIRE
- 27 ASSEMBLING THE HANDRAILS

- APPENDIX A TECHNICAL DRAWING: THERMO SOVRANA
APPENDIX B REAR VIEW OF APPLIANCE

ANNUAL SERVICE RECORD
LIMITED WARRANTY

1. TECHNICAL DATA

	THERMO SOVRANA	SOVRANA
Nominal heat output to room (kW)	6.5	6.5
Nominal heat output to water (kW)	7	N/A
Flue diameter MINIMUM An adaptor is required for the initial connection. (117mm to 5")	5 inch	5 inch
Efficiency %	79	78.7
Maximum fuel load of wood to maintain nominal output (Kg / hr)	4.2	2
Temperature exhaust gas – wood (°C)	190	270
Optimal working temperature	70° - 75°	N/A
Boiler capacity (litres)	11	N/A
Flow & return pipe fitting (female)	1 inch B.S.P.	N/A
Flue draft Pressure (tested when hot) WOOD (mbar/Pa)	0.17 – 2 17 – 20	0.10 – 1.2 10 – 12
Minimum flue height in meters (straight)	5	5
Maximum allowable water pressure (bar)	1.5	N/A
Stove height in mm (to top of closed lid)	890	850
Stove height in mm (to top of open lid)	1470 (890 + 570)	1420 (850+580)
Stove width in mm (incl. rails)	964	970
Stove depth (mm)	641	600
Stove Weight (Kg)	150	130
Grate type	FLAT	FLAT

Please refer to the technical drawings at the end of these instructions for dimensions that are not listed here

2. HEATABLE AREA (VOLUME)

The heating capacity of rooms according to DIN 18893 for buildings in which the insulation is below the levels recommended in the regulation is:

<u>THERMO SOVRANA</u>			<u>SOVRANA</u>		
(120 BTU/m ³)	Well insulated:	387 m ³	(120 BTU/m ³)	Well insulated:	186 m ³
(160 BTU/m ³)	Average insulation:	290 m ³	(160 BTU/m ³)	Average insulation:	107 m ³
(200 BTU/m ³)	Poor insulation:	232 m ³	(200 BTU/m ³)	Poor insulation:	73 m ³

With adequate insulation, these values will be higher. With temporary use, the capacity is reduced by around 25%.

3. KEY ENVIRONMENTAL CONSIDERATIONS

To minimize the impact on the environment the following issues need to be considered when proposing to install a solid fuel appliance:

- Local authorities (Councils) must be consulted for any restrictions that may apply to the use of solid fuel appliances in certain areas such as smoke free zones.
- The appliance must be correctly sized to suit the space and necessary clearances must be strictly adhered to.
- The appliance and flue system must be correctly installed to the current regulations in force at the time.
- The appliance must be correctly operated.
- The appliance and flue system must be properly maintained.
- It is also important to ensure that the dwelling to be heated is well insulated and is as energy efficient as is practical before a heating appliance is chosen and installed.
- The correct fuel must be used.

4. TECHNICAL DESCRIPTION - THERMO SOVRANA

This appliance allows for cooking on the top of the stove or in the oven, as well as providing a source of supplementary heating. They are ideal for holiday apartments and second homes or even as all year round auxiliary heating. This appliance has been designed to burn wood as it's primary fuel source. The stove has air regulators to adjust the combustion. The appliance is made from enamelled galvanized steel, with a cast iron cooking surface/hob. The hob rings are removable for easy cleaning and maintenance. The firebox consists of corrugated steel and a cast iron grate. The appliance has a height adjustable grate. There is a slim warming drawer that is the full width of the appliance. The firebox and the oven door are glass fronted (heat resistant to 700°C) allowing a fascinating view of the flames in the fire box whilst preventing any escape of sparks or smoke. The glass fronted oven door will enable you to see your food being cooked. The heat is provided by radiation through the glass door and from the hot external surfaces of the appliance.

4 A TECHNICAL DESCRIPTION - SOVRANA

This appliance allows for cooking on the top of the stove or in the oven, as well as providing a source of supplementary heating. They are ideal for holiday apartments and second homes or even as all year round auxiliary heating. This appliance has been designed to burn wood as it's primary fuel source. The stove has air regulators to adjust the combustion. The appliance is made from enamelled galvanized steel. The cooking surface on the top of the appliance is bare cast iron and the hob rings are removable. The firebox and the grate is cast iron. Inside is a flat cast iron grate. There is a slim warming drawer that is the full width of the appliance.

The firebox and the oven door are glass fronted (heat resistant to 700°C) allowing a fascinating view of the flames in the fire box whilst preventing any escape of sparks or smoke. The glass fronted oven door will enable you to see your food being cooked. The heat is provided by radiation through the glass door and from the hot external surfaces of the appliance

5 THE 'AIR' CONTROLS

The stove is fitted with various air controls that adjust the flow of combustion air into the unit. It is very important that these controls are fully understood in order to achieve the best results from the appliance.

When operating the controls, ensure that they are used in small increments and not changed by large amounts suddenly. Do not use them like an on – off switch.

It is important that the controls are used correctly, in order to prevent over-firing and to get the best results.

The air controls are as follows:

- PRIMARY AIR CONTROL (FIG 1)
- SECONDARY AIR CONTROL (AIR WASH) (FIG 2)
- OVEN / HOTPLATE CONTROL (FIG. 3)

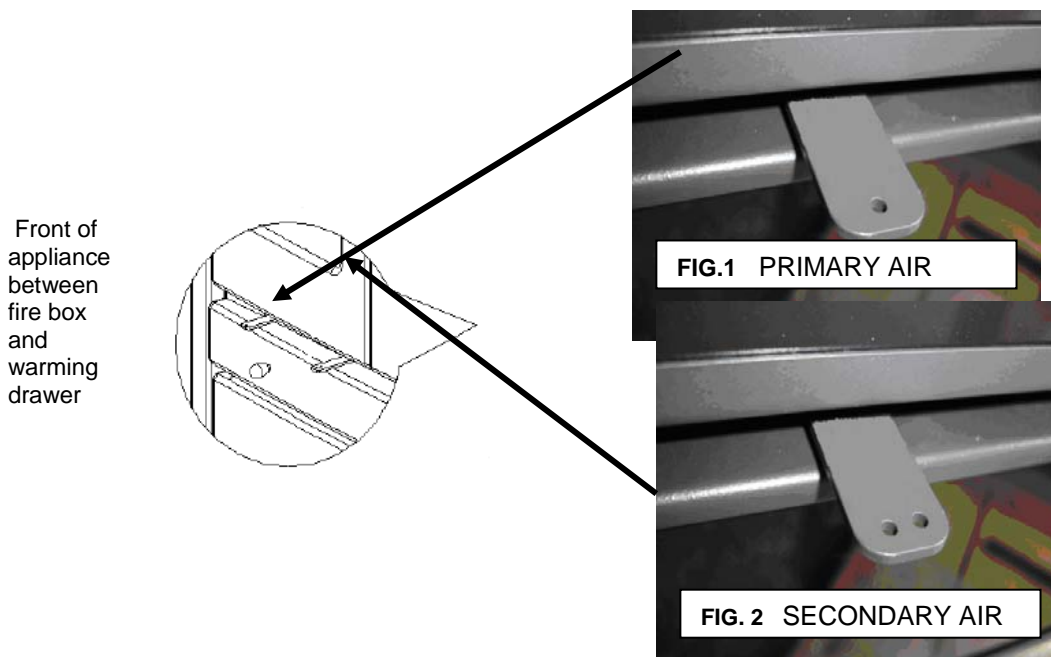

5 A THE PRIMARY AIR CONTROL see FIG.1

The primary air regulator is found on the front of the main fire door and is in the form of a lever. This control will primarily be used when lighting and establishing a fire. Once a fire is well established and the and the combustion gasses are being drawn up the chimney sufficiently, this control will normally be closed and the fire now controlled using the Secondary air control.

5 B SECONDARY AIR CONTROL see FIG. 2

The secondary air regulator is found on the front of the main fire door and is in the form of a lever. This control will primarily be used to control the combustion inside the firebox (once the fire is established). Combustion air entering the stove through this vent will be directed down the inside of the glass panel, this is known as the 'air wash system'. It helps to keep sooty deposits from sticking to the glass and obscuring the view of the flames. Having clean glass also improves the heat radiation through it.

5 C OVEN / HOTPLATE BYPASS CONTROL see FIG 3

This control is positioned on the front of the appliance as shown in the FIG. 3. It has two settings. The hot gasses generated by the burning fuel can be diverted using this control, to give greater heating to the hob or to the boiler. You must only use this control when you have a clean burning, established fire. Look at the smoke coming out of your chimney if you are unsure whether your appliance is burning cleanly. There is a small plate that has two symbols on it representing a frying pan and a casserole dish. The frying pan symbolises the hob and the casserole dish, the oven.

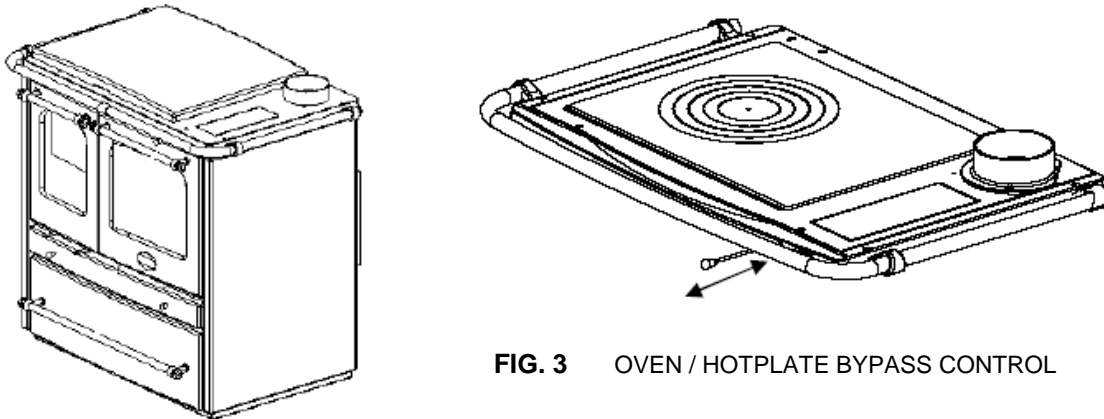

FIG. 3 OVEN / HOTPLATE BYPASS CONTROL

- **HOB COOKING ONLY:**

When the bar is pushed in towards the back of the cooker, the combustion gasses flow over the top of the oven and directly into the flue and up the chimney, heating the hob only. This is the position the lever needs to be in when first lighting the appliance.

- **OVEN COOKING:**

When the control bar is pulled out, the hot combustion gasses flow around the oven, heating it, then they exit the stove. This control must only be operated when the fire is established and burning clean and HOT.

5 D OVER-FIRING WARNING

IT IS EXTREMELY IMPORTANT NOT TO LEAVE ALL OF THE AIR CONTROLS FULLY OPEN. LEAVING THE AIR CONTROL FULLY OPEN WILL LEAD TO "OVER-FIRING". OVER-FIRING IS CAUSED WHEN TOO MUCH HEAT IS GENERATED WITHIN THE FIRE CHAMBER, THIS WILL LEAD TO WARPING, BUCKLING AND GENERAL DAMAGE TO THE STOVE AND ITS INTERNAL COMPONENTS. OVER-FIRING CAN ALSO BE CAUSED BY RUNNING THE APPLIANCE WITH THE DOOR(S) OPEN OR IF YOU HAVE AN EXCESSIVE FLUE DRAW. PLEASE NOTE ANY DAMAGE TO THE APPLIANCE CAUSED THROUGH OVER-FIRING WILL NOT BE COVERED BY THE WARRANTY.

6 ADVICE ON DIVERTING THE HOT FLUE GASSES.

The oven and boiler heats up by having the hot gasses, that are given off the by the burning fuel, being diverted around the channel within the appliance. The operator must only send clean gasses around this channel. This is achieved by burning the correct fuel efficiently and not diverting the gasses too soon. A slow burning fire will produce black smoke, so will burning wet, green, unseasoned wood with a moisture content of more than 20%. Sending this black smoke around the channel will tar it up and the result will be a poor transfer of heat to the boiler, the hob and oven. It is therefore critical that you establish a strong burning fire before diverting the gasses.

7 FUEL OPTIONS

These appliances have been developed to burn wood as the primary fuel. The results quoted in our literature are from test firings using beech logs with a moisture content of less than 20%. You will need to use good quality fuel in order to get the best results from your stove. Seek advice from your local fuel merchant as he will be able to advise you on what fuel to use. Never burn wood that contains paint or any other chemicals.

Damage caused by overheating is not covered by the guarantee.

You should therefore always use the appliance with the door closed to avoid this, control the combustion rate of the appliance by correct use of the air controls and ensure that the flue draught is not excessive.

8 BURNING WOOD

Hardwoods have exactly the same calorific values as softwoods; however softwoods will burn nearly twice as fast as hardwoods meaning more frequent re-fuelling. Most firewood you purchase will be green and have a fair amount of water content. It will need to be stored in a well ventilated shelter to season it. Wood used in this appliance must have a moisture content of less than 20%. Damp or wet wood will quickly form tar deposits on all the internal areas where the combustible gasses travel, preventing the efficient release of heat from the appliance. The inside of the chimney/flue will also be coated, there is a greater risk of a chimney fire occurring. Always use good quality wood, store it under cover in a well ventilated area. Avoid burning oak bark, as this forms tar at a very fast rate.

When selecting wood, also take into consideration ease of splitting, ease of ignition and burning, how much smoke it produces and its "coaling" qualities. "Coaling" refers to the ability of a species of wood to form a long-lasting bed of hot coals when burned. Coaling qualities improve with wood of a higher density. Wood is not a long burning fuel and so it is not always possible to keep the stove in overnight.

9 INITIAL BURNING AND CURING OF THE APPLIANCE

The first time that the appliance is lit, there will be an odour given off. This is the components of the appliance curing. It will be necessary to ventilate the room in which the appliance is sited.

The first firing needs to be done carefully to allow all of the components of the appliance to settle gradually. Never try to run the appliance flat out the first time you light it. It will be necessary to keep the fire burning for longer periods rather than short periods the first four to five times. This will be the best way to achieve correct settling of the appliance. Do not burn the appliance at an accelerated rate; a steady burn is all that is required.

Gradually build up the output of the fire so that no sudden stresses are put on the components of the appliance.

10 USING YOUR STOVE - IMPORTANT NOTES:

This appliance must be installed and commissioned by a fully qualified, registered engineer. HETAS engineers are recommended by Broseley Fires. For your nearest search www.hetas.co.uk

THE SURFACES OF THIS APPLIANCE GET HOT WHEN THE APPLIANCE IS LIT. PLEASE ENSURE THAT CHILDREN, THE ELDERLY, INFIRM AND PERSONS OF LIMITED INTELLIGENCE ARE MADE AWARE OF THIS.

USING YOUR STOVE - IMPORTANT NOTES:

- When lit, all surfaces of the appliance will get hot.
- Serious damage may result if the appliance is left running with the air controls fully open for extended periods.
- Make sure that none of the doors are left open while the appliance is in operation.
- Never leave the appliance unattended during the initial lighting sequence.
- Do not attempt to open the door immediately after igniting the fire. This could cause a flame flash out.
- Always wear the protective gloves when operating the appliance.
- Never burn wood containing paint, glue or any other chemicals.
- Do not overload the appliance with fuel.
- Never use chemicals or fluids such as gasoline, charcoal lighter, drain oil or kerosene to light a fire.
- Using the appliance on a very low output will cause excessive amounts of tar to build up inside the flue and can be a serious fire risk, as this will fuel a chimney fire. You will need to have the flue cleaned and serviced more regularly.
- Never overload the stove (consult the technical table - maximum allowable quantities)
- We advise that you have the appliance serviced annually by a competent heating engineer before the beginning of a new heating season.
- Do not cover the permanent air vent that your heating engineer has installed; this is necessary for the correct combustion of the appliance and your safety.
- Do not light the fire if there is a risk that any part of the system is frozen.
- Never block the permanent air vent that your HETAS engineer installed in the same room as the appliance.

11 LIGHTING AND MAINTAINING A LOG FIRE

All chimneys and flues act differently. After a while, you will find out how your unit works best for starting. Ensure that the draught measurement is correct at the time of installation.

- Use scrunched up paper and dry kindling or fire lighters to start the fire. Lay these on the grate.
- Open the primary and secondary air controls to the fully open position. The flue bypass control **MUST** be pulled out to the open position and left in this position until there is a strong established fire in the firebox.
- When the fire is burning hot, add small pieces of very dry wood, preferably hardwood as these generate better embers.
- Keep all the draft controls fully open till a bed of hot, glowing embers is established.
- Once you have some red hot burning embers, open the door and rake the embers evenly over the grate before adding larger pieces of wood.
- We suggest that you do not fully load the appliance until you have become completely familiar with the operation of ALL the controls.
- For best results, in an ideal situation, open the secondary air control and close the primary air control. The output of the appliance can now be controlled using the secondary air control. The secondary air control will help keep the glass clean as it incorporates 'air wash' technology.
- Do not open the loading door too quickly when reloading the appliance as this can cause flames to flash out the door.
- Do not overload the appliance.
- Do not burn painted or varnished woods, MDF, oak bark or any wood with more than 20% humidity.

12 ASH REMOVAL – CLEANING OUT THE ASH

The removal of the ashes should be done when the appliance is cold. Ashes must be removed periodically for the correct and efficient operation of your appliance. Don't wait till the ash pan's completely full. The frequency of this ash removal will depend on the type of wood being burned as Softwoods and hardwoods will create differing amounts of ash. Keep in mind that cleaning your appliance boosts its efficiency, as ash, soot or tar deposits will block the heat from coming out of the appliance, the boiler and oven will become insulated by the deposits. Excess ash in the pan can potentially cause a fire to go out and may cause severe damage to the grate. It may also prevent the ash door from being shut correctly. Periodical inspection of the ash chamber is recommended. Take care when removing the ash, as small bits of hot embers can stay dormant for long periods when buried in ashes. These will then flare up again when exposed to oxygen, some knowledge of proper ash removal is required for safety. Here are the important points:

Remove ashes to a metal container using a small trowel. Never vacuum the ashes unless it is a genuine 'Ash Vac'. This is a vacuum that is specifically designed for ash removal.

Place the filled ash bucket on a non-combustible surface, fit a lid for extra safety. When cold enough, dispose. For your own protection, a pair of heat proof gloves and a dust mask may be necessary.

13 ASH DISPOSAL

The best thing to do with your ashes is to put them in your garden. Wood ashes are high in potassium, calcium, sodium, magnesium, and phosphorus. Wood ash will make your soil more alkaline.

If you have no garden, you can dispose of completely cold ash with your household trash.

Place it in a tightly closed bag to keep it contained. Always ensure that there are no hot embers left buried in the ash before you transfer it into a flammable bin bag.

14 OPERATING IN TRANSITION PERIODS (Summer)

When the outside temperature gets to be more than the temperature within the property, there is a strong possibility of the flue working in reverse. If the appliance is not lit, this will cause the draught of the flue to travel in a downward direction and the smell of smoke may be obvious in the room.

If you experience problems lighting the appliance, then it will be necessary to warm the flue before loading the appliance with kindling. There are various methods for this procedure. Ask your local supplier or registered chimney sweep for advice.

If the fire is lit, the heat output of the appliance is often reduced and the exhaust gases may not come out the chimney completely. This can cause them to come back into the room.

In this case:

- shake the embers more frequently,
- increase the air for combustion
- only load a reduced quantity of fuel.

This will help to keep the chimney hot and working efficiently.

Check that all the seals of the appliance are in good order and that the connections to the chimney are also sound.

15 MAINTENANCE - CLEANING THE APPLIANCE

Take great care choosing the products to clean your appliance. A major amount of cleaning can be carried out using hot soapy water and a soft cloth. Do not leave the appliance surface wet after cleaning; this may cause uncoated surfaces to go rusty. Using the wrong products on certain surfaces may cause damage to them, so take care when choosing a cleaner. Never use bleach or chlorine based products, caustic cleaners, paint solvents, biological powders, coarse abrasives or salt to clean your appliance. Never mix different products as they may cause a chemical reaction with each other and cause harm to either you or the appliance. Read below to see specific cleaning techniques. *For any further information, please contact your Dealer!*

15 A A DAILY CARE

To keep the surfaces of your appliance clean, a daily wipe over with a lint free cloth is all that is needed. Clean the surfaces when the appliance is cool. A wet cloth may be used on certain surfaces, never leave any surface wet after cleaning as this may go rusty.

To buff the cleaned surfaces, a soft, dry, lint free cloth should be used. Try not to use excessive amounts of water when cleaning the appliance. Wipe up any spills or condensation streaks as soon as is safe to do so. (i.e. when the unit is cold) This will prevent the mark burning onto the appliance and becoming a much tougher stain to remove at a later date, or causing a permanent mark.

15 B CLEANING AND MAINTAINING THE APPLIANCE

The appliances have three main surface finishes; these should be cleaned when the appliance is cool. Please follow any instructions to the letter for any special cleaning agent that you may use. Ash removal and chimney maintenance are also important areas to be aware of to ensure the efficient and correct operation of your appliance. Please read on....

15 C CAST IRON

This can be cleaned with a lint free damp cloth. Don't leave this surface wet as it will go rusty. If it is cleaned when the appliance is slightly warm, the damp surface will dry by itself. Otherwise, wipe the surface dry after cleaning. Another method is to brush the surface with a soft brush. This is good for cleaning in the more detailed and difficult to get to areas. If cast iron is left for long periods in a damp atmosphere; such as a fireplace; it may start to show signs of rust. To prevent this, wipe the surface over with light oil. This will burn off when the fire is re-lit.

15 D ENAMELED SURFACE:

These can also be cleaned with lint free damp cloth and then wiped over with a dry cloth.

15 E GLASS CLEANING:

Only clean the glass when the appliance is cold. There are various glass cleaners you can buy at stove shops that are specially designed to remove hydrocarbon (soot) and fly ash (mineral) deposits from the glass. Follow the manufacturer's instructions. Typically, just spray a small amount of cleaner on the glass and use a paper towel or rag to wipe it clean. Alternatively use a proprietary ceramic hob cleaner such as Hob-brite, as used for ceramic hobs. Follow the directions on the product. If you break the glass, do not use the appliance until the glass has been replaced. Contact your dealer to order the replacement glass.

15 F ASH REMOVAL:

The efficient operation of your appliance is dependant on its correct installation, operation and maintenance. Leaving soot to accumulate inside your appliance will drastically reduce the output of the appliance and prevent it from doing what it is designed to. Ensure that the ash inside every part of the appliance is removed, not just the ash pan.

15 G FLUE MAINTENANCE:

Call a certified chimney sweep (National Association of Chimney Sweeps) or other qualified professional to clean the flue system. These professionals have the equipment and the experience to do a thorough job. The sweep will advise you as to the intervals that you should have your flue swept. We would recommend that you have it swept at least twice a year, but you may need to sweep it more.

Get them to inspect the condition of all the associated chimney items and report to you on their condition. Be sure to check the pipe at least once every six months to determine if it has corroded.

15 H ROPE SEALS:

For the appliance to operate correctly, it is important that all the seals; where fitted; are in good condition and are sealing correctly. They should be replaced if they are showing excessive signs of fraying and are not making a good seal. They are glued into position using a high temperature, flexible, silicone sealant

15 I AIR CONTROLS:

Ensure that all the air controls operate smoothly and are free from ash or other foreign bodies. Pay particular attention to the damper flap at the rear of the ash drawer. Clean this area with care and ensure that excessive amounts of ash are kept from building up and affecting the operation of this control.

15 J CLEANING THE SMOKE CHANNEL

The area around the oven where the smoke travels will need periodical inspection and cleaning. If the smoke sent round this area needs to be hot and clean, major deposits around this channel is an indication that the appliance is not being used correctly. This channel is similar to your chimney, a stiff brush should be all you need to clean it out. Removing the hob rings will give you access to the top and side of the oven channel. The bottom of the oven can be removed by taking out the two Phillips screws at the front of the oven base, lift out the base to expose the area under the oven. If you need to reintroduce the seal around this base plate when re-fitting after cleaning, a high temperature silicone sealant that withstands temperatures up to 300°C and conforms to the regulations relating to its use in areas where food contact is likely.

16 SPARES

THE APPARATUS MUST NOT BE MODIFIED. ONLY USE SPARE PARTS EXPRESSLY AUTHORISED AND SOLD BY BROSELEY FIRES LTD. CONSULT YOUR LOCAL AUTHORISED DEALER FOR ADVICE.

Broseley Fires can supply an exploded drawing of the components that make up the appliance.

17. INSTALLATION OF THE APPLIANCE

THIS APPLIANCE MUST BE INSTALLED AND COMMISSIONED BY A FULLY QUALIFIED, REGISTERED ENGINEER.

The guarantee is void if any part of the installation is found to be illegal.

- This appliance must be installed into a '**Class 1 Chimney**'. If there is no existing chimney, then an approved solid fuel, factory built, prefabricated block type or a twin walled, stainless steel flue can be used. Get advice from a qualified chimney engineer. Flue sharing is not allowed.
- The flue diameter of these appliances must be a minimum of 5 INCH diameter.
- **An adaptor is required for the initial connection. (117mm to 5") a 4" to 5" adaptor may suffice.**
- If excessive draw is present, then a suitable 'flue draught stabilizer' should be fitted.
- If the chimney suffers from down draught, then a special 'anti-downdraught' cowl will need to be fitted. In exposed windy locations, a 'stabilizing' cowl may need to be fitted. The minimum cowl requirement that we recommend, is a rain cowl with a bird guard.
- To perform satisfactorily, the chimney height must not be less than 5 meters from stove to cowl. If there are any bends in the flue, this minimum length will need to be increased by 1 meter for each bend.
- The initial connection to the appliance will need to be 600mm vertical before any bend.
- A soot door will be required to facilitate the sweeping of the flue.
- A maximum of four 45 degree bends is allowed in any complete flue; from stove to cowl.
- Adequate access for sweeping the flue, such as a soot door, must be provided.
- Flue pipe should be fitted inside the flue pipe collar (spigot) to prevent creosote and condensates from running down onto the top of the appliance. (see specifications for exact collar sizes)
- All flue pipe must be suitable for solid fuel (complies with latest European regs.) and fitted in accordance with building regulations, whilst complying with current legislation and manufacturers' instructions.
- If a rear flue is able to be fitted, the horizontal length must be no longer than 150mm.
- If there is additional ventilation in any room, this will create air depression and the risk of the products of combustion being drawn into the room Mechanical ventilation in the same room as any solid fuel appliance must be avoided.
- This appliance should be connected to an open vented system in line with building regulations and any other regulations that are in force at the time should be observed.

The use of this equipment as a stove only is not recommended. For no region should the stove be lit before it has been filled with water. To attempt this could result in serious damage.

18 FLUE REQUIREMENTS

This appliance has a European sized flue collar that is metric in size. An adaptor is required for the initial connection to the flue collar. The adaptor for this appliance will be a standard 5 to 6 inch adaptor. This appliance requires a minimum flue diameter of 6 inches. The draw of the chimney should be at least 17 Pa (1.7mm H₂O) The measurement must always be done when the stove is hot (producing nominal heat values). When the pressure exceeds 20 Pa (2.0mm of a column of water) it will be necessary to reduce it by the addition of a flue draught stabilizer.

Installation, construction, and maintenance of chimneys and flues must comply with Building regulations 'Approved Document (ADJ)' Any domestic solid fuel appliance will only work efficiently when connected to a chimney system capable of generating adequate up-draft to induce sufficient air supply for complete combustion and to overcome any friction resistance associated with the system. The chimney is one of the most important parts of the installation; great care should be given to its design. The chimney must be thoroughly swept, checked for soundness and suitability, before any connection is made to the appliance. This must be carried out by a qualified person. If re-using an existing flue, the flue and the chimney should be checked and if necessary, altered to ensure that they satisfy the requirements for the proposed use. Lining a defective flue is an option.

19 LINING THE FLUE

An independently certified flexible metal liner can be used to reline a chimney. An insulated chimney is the most efficient and safe way to burn wood.

Tar deposits condense in a cool chimney. An insulated chimney helps prevent these deposits.

A standard chimney will gradually get saturated in tar, this is a fire hazard.

Tar stains may appear on the surface of the chimney breast inside the property.

20 FLUE TERMINATION

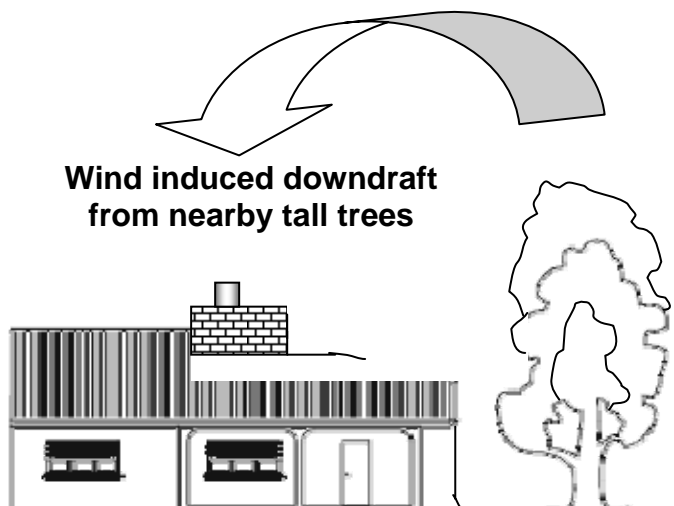

The height and termination of the flue is an important part of the installation and consideration needs to be made to ensure that the flue is high enough to create sufficient draft to clear the products of combustion. The termination of the flue outlet position which can meet the requirements in common circumstances are shown in Document J. If there are unusual circumstances that will affect the efficient and safe removal of the products of combustion; the height and/or the separation distances shown in Document J may need to be increased.

24 PROVISION OF A NOTICE PLATE

A notice plate must be durable and be fixed on site, where a hearth, fireplace flue or chimney is provided or extended (including cases where a flue is provided as part of refurbishment work). Building regulations states that the responsibility for achieving compliance with the requirements of Part J rests with the person carrying out the work and so this person must be competent in the work they are being asked to do.

21 SITING THE APPLIANCE

This appliance must not be fitted into a location where it will be impossible to service. The location must comply with the requirements laid down in the Building Regulations.

22 HEARTH REQUIREMENTS

It is essential that the hearth / base on which the appliance will stand is strong enough to support the weight of the appliance and the chimney / flue. In certain circumstances, it may be necessary to support the flue pipe with brackets. The hearth must be level and made of a suitably robust, non combustible material.

The positioning of the appliance and dimensions of the hearth must comply with current building regulations.

This appliance does not cause the hearth to exceed 100° C.

Manufacturer's instructions relating to clearances must be adhered to.

23 STOVE CLEARANCES

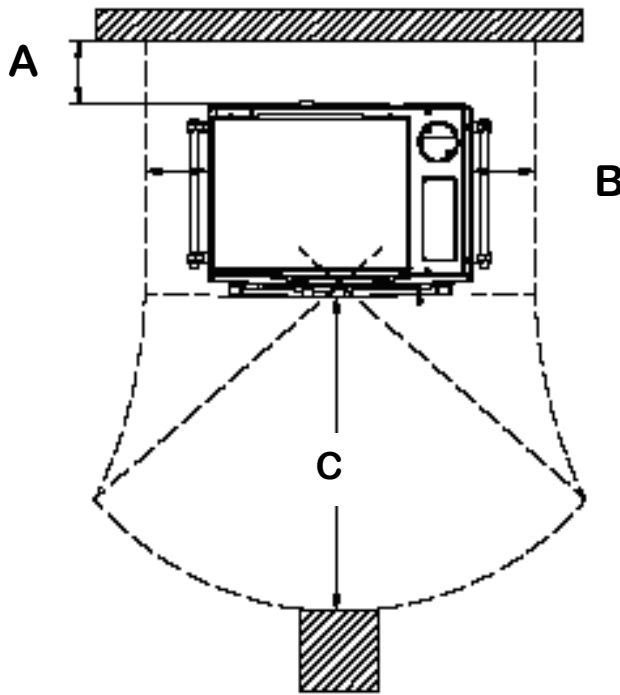

STOVE CLEARANCES TO FLAMMABLE MATERIALS

CLEARANCE 'A' TO REAR	CLEARANCE 'B' TO SIDE	CLEARANCE 'C' TO FRONT
200 mm	200 mm	1000 mm

STOVE CLEARANCES TO NON - FLAMMABLE MATERIALS

CLEARANCE 'A' TO REAR	CLEARANCE 'B' TO SIDE	CLEARANCE 'C' TO FRONT
100 mm	100 mm	300 mm

Where the hearth abuts a wall and the appliance is more than 50 mm but not more than 300 mm away;

- The thickness of the wall needs to be at least 75 mm
- The height of the wall needs to be at least 1.2m above the hearth.

PLEASE REFER TO BUILDING REGULATIONS "WALLS ADJACENT TO HEARTHES" for further information on this subject.

24 ADDITIONAL VENTILATION

There must be sufficient free air for combustion into the room where the appliance of 5Kw or more is installed. THIS IS A LEGAL REQUIREMENT.

Permanent openings or vents must not be covered. Vents needs to be positioned carefully, they must be protected from direct wind conditions. A baffle that has been specially designed to fit over the vent will protect it from the effects of wind, but must not restrict the total vent area and must be secured in a way that prevents its movement. Regular inspection of any vents is critical to ensure that the vent has not become restricted.

The appliance may require up to 20 m³/hour of combustion air. The natural recirculation of air must be guaranteed by having permanent ventilation to the outside.

An extractor fan, cooker hood or similar product, installed in the same room, or in a room nearby; that sucks air out (aspirating); may negatively affect the functions of your appliance.

If the room contains more than one appliance; of the type that requires combustible air; a calculation will need to be made to re-calculate the permanent air vent requirement.

Please see the 'Technical Data' list at the front of these instructions or refer to current building regulations for fixed additional ventilation requirements.

25 CHIMNEY FIRE

If a chimney fire occurs in the flue or the chimney:

1. Immediately shut off the air supply by closing all dampers and air openings on the stove.
2. Ensure the main door and ash door are securely closed.
3. If the fire in the stove or fireplace can be extinguished safely; with a CO2 extinguisher; put it out as quickly and safely as possible. Do not attempt to put out the fire using water.
4. Close all windows and doors to the room.
5. **Call the fire brigade**

When the chimney has stopped burning have it checked by a specialist for possible cracks or leaks. Please review the way you are using the appliance and check that the fuel you are using is suitable. Chimney fires only occur if the appliance has been wrongly installed , maintained or operated. Damage caused to an appliance where a chimney fire has occurred are not covered by any guarantee.

- Please comply with the technical data given in this instruction manual.
- Illegal installations are not covered by any sort of guarantee.

26 ASSEMBLING THE HANDRAILS

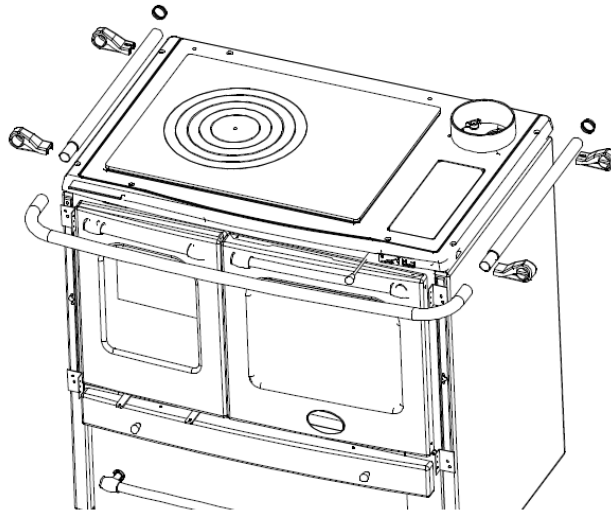

APPENDIX A TECHNICAL DRAWING: THERMO SOVRANA
APPENDIX B REAR VIEW OF APPLIANCE

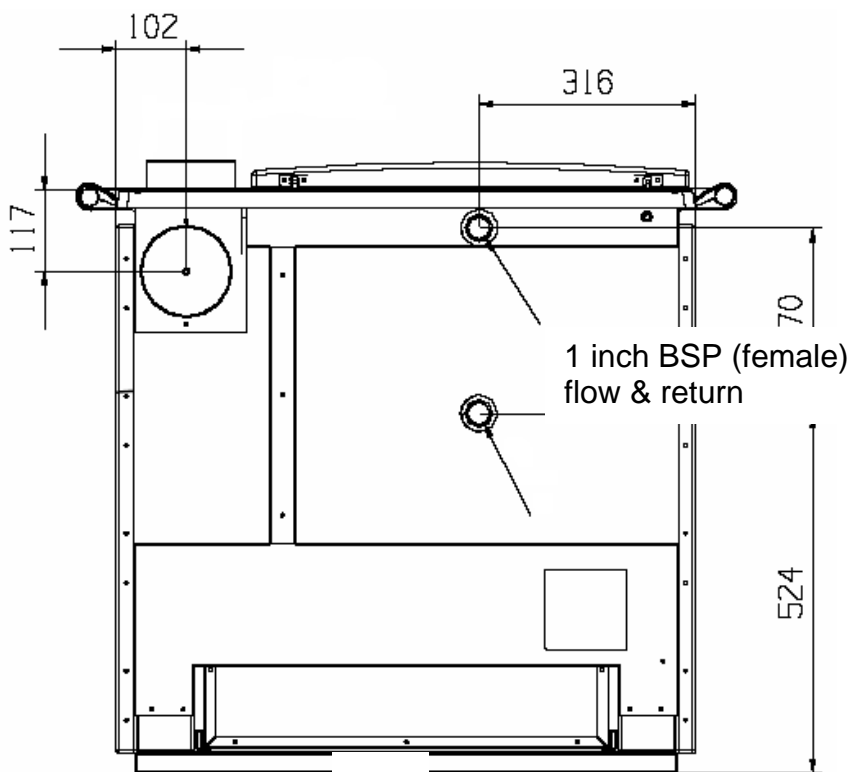
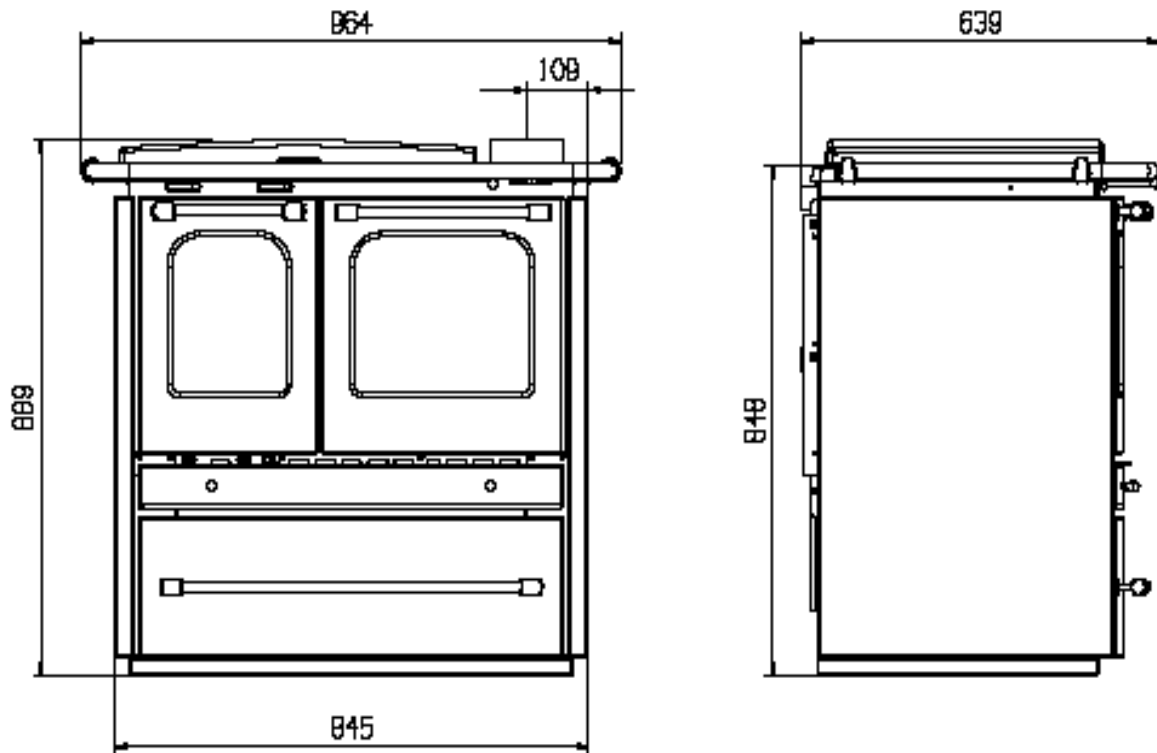

GRATE ORIENTATION

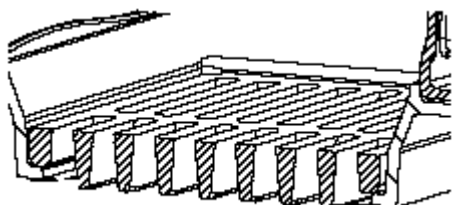

Ensure that the grate is in the right way up; the small slot should be at the top so that small embers fall through and do not get snagged in the grate.

ANNUAL SERVICE RECORD

A "Declaration of Completion" Certificate must be obtained for the installation and retained by the end user. Failure to comply with these requirements may void the warranty.

INSTALLATION DATE OF APPLIANCE: _____

INSTALLATION DATE: _____

HETAS ENGINEER: _____ . . REG. No. _____

COMPANY NAME: _____ .

COMPANY ADDRESS: _____ .

_____ .

POSTCODE: _____

CONTACT NUMBER _____

1ST YEAR SERVICE completion date: _____

SERVICE ENGINEER: _____ . . REG. No. _____

COMPANY NAME: _____ .

COMPANY ADDRESS: _____ .

_____ .

POSTCODE: _____

2ND YEAR SERVICE completion date: _____

SERVICE ENGINEER: _____ . . REG. No. _____

COMPANY NAME: _____ .

COMPANY ADDRESS: _____ .

_____ .

POSTCODE: _____

3RD YEAR SERVICE completion date: _____

SERVICE ENGINEER: _____ . . REG. No. _____

COMPANY NAME: _____ .

COMPANY ADDRESS: _____ .

_____ .

POSTCODE: _____

4TH YEAR SERVICE completion date: _____

SERVICE ENGINEER: _____ . . REG. No. _____

COMPANY NAME: _____ .

COMPANY ADDRESS: _____ .

_____ .

POSTCODE: _____

5TH YEAR SERVICE completion date: _____

SERVICE ENGINEER: _____ . . REG. No. _____

COMPANY NAME: _____ .

COMPANY ADDRESS: _____ .

_____ .

POSTCODE: _____

6TH YEAR SERVICE completion date: _____

SERVICE ENGINEER: _____ . . REG. No. _____

COMPANY NAME: _____ .

COMPANY ADDRESS: _____ .

_____ .

POSTCODE: _____



LIMITED WARRANTY

A "Declaration of Completion" Certificate must be obtained for the installation and retained by the end user. Failure to comply with these requirements may void the warranty.

You, as the end user, have a contract by law with the supplier / dealer from whom you purchased the product. That dealer then has the same contract with the manufacturer or wholesaler and these have a contract with their suppliers. ALL CLAIMS MUST FOLLOW THIS PROCEDURE.

Thank you for choosing a Product from **Broseley Fires Ltd.** This warranty gives you specific legal rights. The statutory rights of the consumer are not affected by the warranty, or the consumers' rights against the dealer arising from their sales / purchase contract.

The manufacturers' warranty:

Your Product will be free from defective parts, material, and workmanship at the time of its original purchase for a period of one (1) year. This Warranty will become active as of one month from the date of delivery.

This warranty does not cover any failure of the unit due to normal wear and tear, misuse, abuse, accident, illegal modification, illegal installation or repair, damage resulting from improper use or failure to maintain the product. Variations in color and texture are a natural characteristic of cast iron products. Colour changes may result from exposure to light and other elements which are a part of the aging process. These material variations and changes are not covered by this warranty.

The consumable items within the product are not covered by the warranty, nor is the glass.

If during the warranty period, this Product fails to operate under normal use and service, due to defects in material and / or workmanship, Broseley Fires will either repair or replace the product.

The repaired or replaced product shall be warranted for the remaining period of the original warranty + the time taken to days from the date of repair, whichever is longer.

Repair or replacement may involve the use of functionally equivalent reconditioned units. Replaced parts or components will become the property of Broseley Fires.

Should you wish to claim under the warranty, please contact the supplier / dealer from whom you purchased the appliance. Do not claim directly to Broseley Fires, as they are unable to process any direct claim from an end user.

Product design and any specifications are subject to change without notice. This is due to our continuous product development and improvement. The buyer will not be entitled to request free upgrades to the new design or compensation for previously purchased products or any products on order.

- This Warranty covers all Broseley Fires costs within the Warranty period.

IN NO EVENT SHALL BROSELEY FIRES BE LIABLE FOR INCIDENTAL OR CONSEQUENTIAL DAMAGES OF ANY NATURE WHATSOEVER, INCLUDING BUT NOT LIMITED TO LOST PROFITS OR COMMERCIAL LOSS, TO THE FULL EXTENT THOSE DAMAGES CAN BE DISCLAIMED BY LAW. (if applicable)

NON - COVERAGE OF THE GUARANTEE

If the end-user's claim should not be covered by this guarantee, the end-user shall be liable for costs incurred by Broseley Fires such as callout and inspection costs for examination of the product, transportation costs of the product as well as any other relevant costs.

If, after having been informed about the non-coverage of the guarantee, the end-user wants to have the repairs done, the end-user shall additionally pay for any spare parts used and for the labour and transportation costs incurred. If repairs are carried out under this guarantee, the remaining guarantee period for the product shall be extended by the period of time that has elapsed since the complaint was officially logged with Broseley Fires until the repairs have been completed

A COPY OF OUR FULL TERMS AND CONDITIONS IS AVAILABLE ON REQUEST.

** End-user means the natural or legal person who owns the product and who has not acquired it with a view to reselling or installing it in the course of business.