

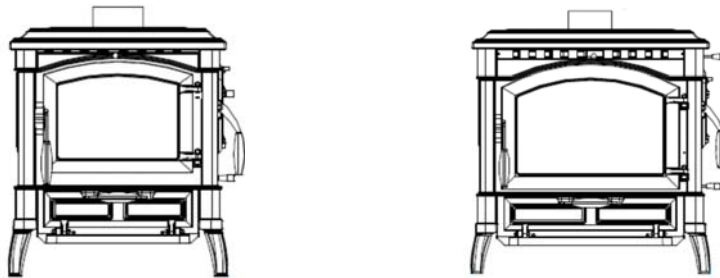

INSTALLATION AND OPERATION INSTRUCTIONS FOR



VERONA 11 & 16 Wood Burning Stoves

THESE INSTRUCTIONS COVER THE HOTPLATE
AND NON-HOTPLATE OPTIONS

PLEASE READ THESE INSTRUCTIONS THOROUGHLY BEFORE INSTALLING, OPERATING OR SERVICING
THIS APPLIANCE.

A "Declaration of Completion" Certificate must be obtained for the installation and retained by the end user. Failure to
comply with these requirements may void the warranty.

Revision: TJ09b

© 2007-2008 Broseley Fires Ltd

INTRODUCTION

The keys to safe, successful and efficient wood burning are good planning, correct installation and proper operation. Please read the following instructions carefully to get the best from your new purchase.

Modern homes have better levels of insulation and are more energy efficient, with more effective and better seals on doors and windows. This makes our homes easier to heat, but also means that solid fuel appliances must be more carefully designed so that they will function correctly in the energy efficient, modern homes of today. The more energy efficient a house is, the less fuel is required to heat it. Less fuel use means less impact on the environment.

The operation of our appliances, so that they do not produce excessive smoke (beyond the initial light up and reloading periods) is most important. When our appliances are not smoking, it is an indication that it is being operated correctly and efficiently.

The flames that are seen inside the appliance are not the fuel burning, but the carbon particles and gases that are released from the fuel once it has been heated to a sufficiently high temperature. The escape of any unburnt particles and some gases into the atmosphere are the cause of air pollution.

Our appliances are designed to ensure that the combustion of all gases and particles takes place within the firebox, to maximize the heat output of the appliance and to minimize the discharge of particulate emissions to the atmosphere.

It is important therefore, for appliances to be operated in accordance with our instructions in a manner that maintains a high temperature in the firebox with an adequate supply of air to ensure efficient combustion. A good indication of efficient combustion is a bright lively flame in the firebox. A dull flame or smoldering fire indicates poor or incomplete combustion.

To maintain adequate heat in the firebox, it is very important to use dry, well seasoned wood with less than 20% moisture content. The wood must be correctly sized for the particular appliance and it also helps to have at least three or four pieces burning at the one time to assist the combustion process.

Adding single pieces of unseasoned or wet wood to a fire will reduce the firebox temperature and prevent adequate combustion. This will result in increased smoke emissions causing the flue and internal components of the appliance to become blocked with tar and creosote more quickly. The tar and creosote deposits in the chimney will fuel a chimney fire.

Please note that it is a requirement under the Broseley Fires Ltd's warranty system that the installation of the stove is carried out by a Competent Person registered with a Government approved Competent Persons Scheme. HETAS Ltd operate such a Scheme and a listing of their Registered Competent Persons can be found on their website at www.hetas.co.uk.

INDEX

- 1. TECHNICAL DATA
- 2. TECHNICAL DESCRIPTION
- 3. HEATABLE AREA (VOLUME)
- 3A. KEY ENVIRONMENTAL CONSIDERATIONS
- 4. THE AIR CONTROLS
- 4A. THE PRIMARY AIR CONTROL (turning valve)
- 4B. SECONDARY AIR CONTROL (slider)
- 4C. THE THERMOSTAT CONTROL (dial)
- 4D. DIRECT FLUE PATH SHUTTER CONTROL
- 5.0 FUEL OPTIONS
- 5A BURNING WOOD
- 5C HOT PLATE OPERATION
- 6.0 INITIAL BURNING & CURING OF THE STOVE.
- 6A USING YOUR STOVE – IMPORTANT NOTES
- 7.0 LIGHTING AND MAINTAINING A LOG FIRE
- 8.0 ASH REMOVAL
- 9.0 WOOD ASH DISPOSAL
- 10.0 OPERATING IN TRANSITION PERIODS (SUMMER)
- 11.0 MAINTENANCE – CLEANING THE APPLIANCE
- 12A RECOMMENDED CLEANING PRODUCTS
- 12B DAILY CARE
- 12C CLEANING THE OUTSIDE OF THE APPLIANCE
- 12D ASH REMOVAL
- 12E GLASS CLEANING
- 12F FLUE MAINTENANCE
- 12G ROPE SEALS
- 12H AIR CONTROLS

- 13.0 INSTALLATION OF THE APPLIANCE**
- 13A FLUE REQUIREMENTS
- 13B LINING THE FLUE
- 14 SITING THE APPLIANCE
- 14A HEARTH REQUIREMENTS
- 15 ADDITIONAL VENTILATION
- 16 FITTING THE SPIGOT AND BLANKING PLATE

**ANNUAL SERVICE RECORD
LIMITED WARRANTY**

1. VERONA 11 & 16 TECHNICAL DATA

Stove Model:	Verona 11	Verona 16
Total power output	11 Kw (37,543 btu)	16 Kw (54,600 btu)
Wood consumption per hour (20% humidity)	2.6 kg/h (MAX)	3.6 kg/h (MAX)
Flue Pipe Diameter	150mm / 6inches	150mm / 6inches
Flue draw (Hot) (Tested after one hour)	1.0-1.2 H ₂ O (water gauge) 10-12 PASCAL	1.0-1.2 H ₂ O (water gauge) 10-12 PASCAL
FREE AIR VENT SIZE	550 mm ² minimum + 550 mm ² per Kw over 5	550 mm ² minimum + 550 mm ² per Kw over 5
TOTAL WEIGHT OF THE APPLIANCE	150kg (without hot plate) 165kg (with hot plate)	190kg (without hot plate) 218kg (with hot plate)
WIDTH	670mm (without hot plate) 670 (with hot plate)	790mm (without hot plate) 800 (with hot plate)
DEPTH	450mm (without hot plate) 590mm (with hot plate)	520mm (without hot plate) 660mm (with hot plate)
HEIGHT from floor to top of lid (with lid shut)	710mm (without hot plate) 760mm (with hot plate)	780mm (without hot plate) 830mm (with hot plate)
TEMPERATURE OF EXHAUST GASSES	WOOD= 332 °C	WOOD= 367 °C

2. TECHNICAL DESCRIPTION

The VERONA 11 & 16 wood burning stoves are suitable for heating living spaces within a home or supporting a central heating system. If fitted with the hot plate the stove will also be suitable for cooking a wide variety of food stuffs. They are ideal for holiday apartments and weekend houses or as a heating system during the whole year.

The VERONA 11 & 16 stove are made of cast iron and plates of steel metal sheet. The fire chamber is internally lined with cast iron firebricks. There is a turning and extractable grate. The stove is equipped with a panoramic door with ceramic glass (resistant up to 700 °C) this allows a wonderful view of the flame picture, whilst also preventing outputs of sparks and smoke. There is also the option of a Verona 11 & 16 stove with a hot plate, allowing you to cook on the stove.

The appliance is equipped with primary and secondary air controls, by which it is possible to control the burn rate and hence the output of the appliance.

3. HEATABLE AREA (VOLUME)

The heating volume of the appliance; according to DIN 18893; will vary depending on the amount of thermal insulation that the property has. Properties with high ceilings, draughty windows and doors, solid brick walls and poor insulation, these are all going to affect the potential maximum heating volume of the appliance.

Property with:

- favourable construction - 186 m³
- less favourable construction - 107 m³
- unfavourable construction: - 73 m³

Using the correct fuel in the appliance, having suitable thermal insulation of the property and complying with the instructions, the heating volume is the greatest.

3A. KEY ENVIRONMENTAL CONSIDERATIONS

To minimize the impact on the environment the following issues need to be considered when proposing to install a solid fuel appliance:

- Local authorities (Councils) must be consulted for any restrictions that may apply to the use of solid fuel appliances in certain areas such as smoke free zones.
- The appliance must be correctly sized to suit the space and necessary clearances must be strictly adhered to.
- The appliance and flue system must be correctly installed to the current regulations in force at the time.
- The appliance must be correctly operated.
- The appliance and flue system must be properly maintained.
- It is also important to ensure that the dwelling to be heated is insulated and is as energy efficient as is practical.
- The correct fuel must be used.

The selection, installation, correct use and maintenance of wood burning appliances and flue systems are discussed in more detail in the following sections of these instructions.

4.0 THE 'AIR' CONTROLS

The stove is fitted with controls that adjust the flow of air into the unit. It is very important that these controls are fully understood in order to achieve the best results from your stove.

When operating the controls, ensure that they are used in small increments and not changed by large amounts suddenly. Do not use them like an on – off switch.

It is important that the following controls are used correctly.

The air controls are as follows:

- PRIMARY AIR CONTROL
- SECONDARY AIR CONTROL (AIR WASH)
- THERMOSTAT CONTROL
- FLUE PATH SHUTTER CONTROL

4A THE PRIMARY AIR CONTROL (lever B)

The primary air control is found to the right of the main door ('B' in the attached diagram), it is in the style of a push/pull lever. This control will be used during the initial lighting phase.

The ash drawer must be regularly emptied, so that the ash does not obstruct the entry of primary air. The chamber in which the drawer is housed will also need to be cleaned on a regular basis, as any ash that spills over the sides of the pan will get pushed to the rear of the chamber and interfere with the thermostat control damper. Failure to keep this area clear will result in the damper being stuck in the open position.

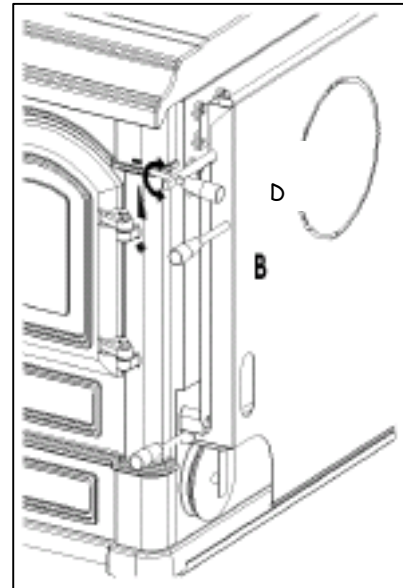

4B SECONDARY AIR CONTROL (slider)

Over the hearth door you will find the 'secondary air control' in the style of a slider. ('A' in the attached diagram)

Combustion air entering the stove through this vent will be directed down the inside of the glass panel, this is known as the 'air wash system'. It helps to keep sooty deposits from sticking to the glass and obscuring the view of the flames. Having clean glass also improves the heat radiation to be uninterrupted. This control will be used to adjust the combustion rate inside the fire chamber.

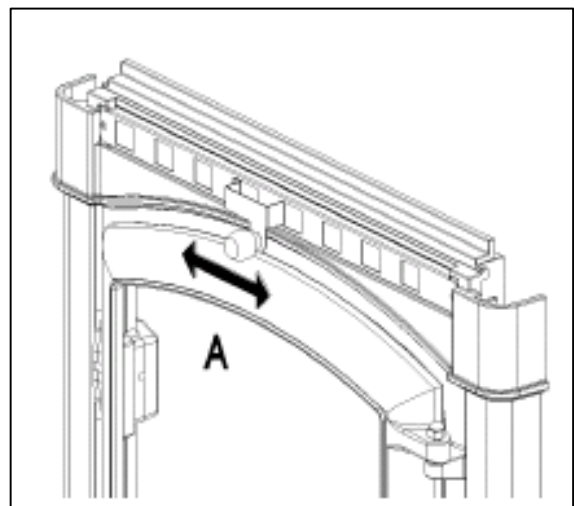

4C THE THERMOSTAT CONTROL (lever)

The thermostat control can be found at the rear of the stove on the right hand side, it is situated above the direct flue path shutter control (see below for position of flue path shutter)

The thermostat control operates a damper that allows air to enter the stove at a controlled rate. It regulates the burn rate of the fire and keeps it at a constant heat output, irrespective of the fuel load (so long as it isn't empty) When wanting to control the stove using the thermostatic control, the primary and secondary air controls can be shut.

According to the chosen position of the thermostat dial, the damper will react slowly and alter the combustible air entering the unit. This is how a fire would naturally respond to changing air supply.

As it is a high precision device we recommend moving the lever slowly and with care and never forcing it.

The thermostat control must not be used to build the fire up suddenly and then shut it down suddenly. This is of no benefit and may cause serious damage to the internal components of the appliance or control.

4D Direct Flue Path Shutter Control (lever C)

This control is used to bypass the baffle within the stove when there is a risk of the chimney being cold and therefore generating little draw; when the stove has not been lit for some time for example. The flue may need a little assistance and therefore, if the shutter is opened before the fire is lit; the warm/hot gasses from the fire will not have to travel around the baffle, losing heat as they go. They can go directly into the chimney where they will heat the chimney and thus generate a good flue draft.

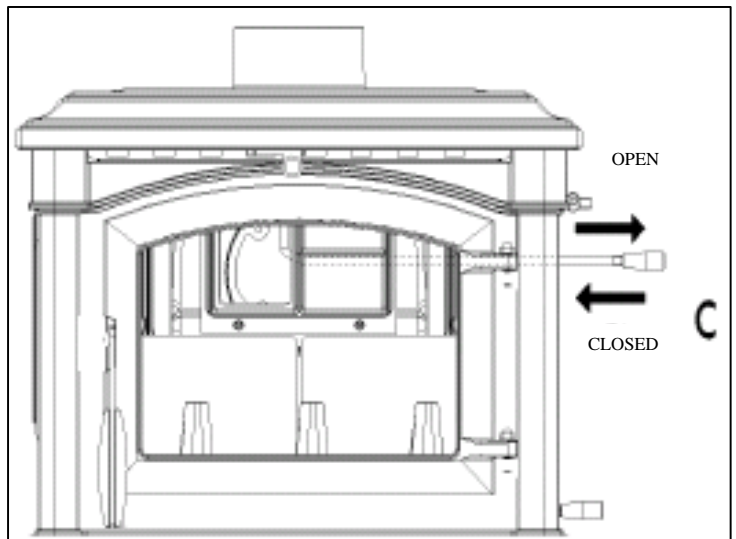

5. FUEL OPTIONS

These appliances have been designed to burn wood as their primary fuel source.

Do not burn wood that contains chemicals (e.g. paint and glue)

You need to use well seasoned wood to get the best results from your stove, logs should have a moisture content of less than 20%.

5A BURNING WOOD

Hardwoods and softwoods both have the same calorific value (by weight), however softwoods will burn nearly twice as fast as hardwoods. Most firewood you purchase will be green and have a fair amount of water content. It will need to be stored in a well ventilated shelter to season it.

Wood used in this appliance must have a moisture content of less than 20%. Damp or wet wood will quickly form tar deposits on all the internal areas where the combustible gasses travel. They will coat the chimney/flue with tar and soot therefore increasing the risk of a chimney fire.. Always use good quality wood, store it under cover in a well ventilated area.

Avoid burning oak bark, as this forms tar at a very fast rate.

When selecting wood, also take into consideration ease of splitting, ease of ignition and burning, how much smoke it produces and its "coaling" qualities. "Coaling" refers to the ability of a species of wood to form a long-lasting bed of hot coals when burned. Coaling qualities improve with higher density.

5C Hot Plate Operation

To operate your hot plate on your stove lift the hot plate cover upwards, always using the glove supplied, until the catch at the rear is locked into place, to prevent the cover from falling. To lower the hot plate, release the catch (using the tool supplied) and slowly lower the hot plate cover back into place, using the glove supplied. Familiarise your self with this operation whilst the stove is cold.

6.0 INITIAL BURNING AND CURING OF THE APPLIANCE

The first time that the appliance is lit, there will be an odour given off. This is the components of the appliance curing. It will be necessary to ventilate the room in which the appliance is sited.

The first firing needs to be done carefully to allow all of the components of the appliance to settle gradually. Never try to run the appliance flat out the first time you light it.

Gradually build up the output of the fire so that no sudden stresses are put on the components of the appliance.

6A. USING YOUR STOVE - IMPORTANT NOTES:

- Serious damage can result if the appliance is left running with the air controls fully open for extended periods.
- Make sure that none of the doors are left open while the appliance is in operation.
- Never leave the appliance unattended during the initial lighting sequence.
- Do not attempt to open the door immediately after igniting the fire. This could cause a flame flash out.
- Always wear the protective gloves when operating the appliance.
- Never burn enhanced fuels such as 'Petrocoke'
- Do not overload the appliance with fuel.
- Never use chemicals or fluids such as gasoline, charcoal lighter, drain oil or kerosene to light a fire.
- Using the appliance on a very low output will cause excessive amounts of tar to build up inside the flue and can be a serious fire risk, as this will fuel a chimney fire.
- We advise that you have the appliance serviced annually by a competent heating engineer before the beginning of a new heating season.

7.0 LIGHTING AND MAINTAINING A LOG FIRE

All chimneys and flues act differently. After a while, you will find out how your unit works best for starting.

- Use crunched up paper and dry kindling to start the fire. Lay these on the grate.
- Open the primary and secondary air controls. The thermostat control should be set to number 5.
- The ignition control should be pushed in. This will open the damper to the chimney fully and create the best condition for the lighting of the fire.
- It will take a few minutes for the fire to establish itself.
- When the fire is burning hot, add small pieces of hardwood.
- Keep all the draft controls fully open till a bed of hot, glowing embers is established.
- Once you have some red hot burning embers, open the door and rake the embers evenly over the grate before adding larger pieces of wood.
- We suggest that you do not fully load the appliance until you have become completely familiar with the operation of ALL the controls.
- For best results, in an ideal situation, open the primary air control one third open and the secondary air control completely open. The output of the appliance can now be controlled using the thermostat control. This is when burning LOGS.
- Do not open the loading door too quickly when reloading the appliance as this can cause flames to flash out the door. This occurs when there is unburned fuel and a large amount of gases in the top of the firebox. When the door is opened, oxygen is combined with the gases and these ignite, causing a 'mini explosion'.
- The maximum size of log, when refuelling an established fire, should be 30 cm's long and 30-40cm's in circumference.
- Do not burn painted or varnished woods, MDF, oak bark or wood with more than 20% humidity.

8.0 ASH REMOVAL

- The removal of the ashes should be done when the appliance is cold.

Ashes must be removed periodically for the correct and efficient operation of your appliance.

Do not wait till the ash pan's completely full. The frequency of this ash removal will depend on the fuel being burned, ie. Softwood or hardwood as they create differing amounts of ash.

Keep in mind that cleaning your appliance boosts its efficiency, as ash, soot or tar deposits will block the heat from coming out of the appliance and the hob.

Excess ash in the pan can cause the fire to go out and may also cause severe damage to your grates. It will also block the damper control located at the rear of the ash pan chamber.

If there is ash inside the ash pan chamber, this will also need removing. If not removed it may get pushed into the damper control aperture; located at the rear of the ash pan chamber; preventing the thermostat control from working correctly. Periodical inspection is recommended.

Take care when removing the ash, as small bits of hot embers can stay dormant for long periods when buried in ashes. These will then flare up again when exposed to oxygen, some knowledge of proper ash removal is required for safety. Here are the important points:

Remove ashes to a metal container using a small trowel. Never vacuum the ashes unless it is a genuine 'Ash Vac'. This is a vacuum you can buy at hearth shops, it is specifically designed for ash removal.

- Place the filled ash bucket on a non-combustible surface such as stone, concrete, brick, or slate, as the heat will transfer through the bottom of the container. Fit a lid for extra safety.

For your own protection, a pair of heat proof gloves and a dust mask may be necessary.

9.0 WOOD ASH DISPOSAL

The best thing to do with your ashes is to put them in your garden. Wood ashes are high in potassium, calcium, sodium, magnesium, and phosphorus.

Wood ash will make your soil more alkaline, so apply it appropriately for your soil.

In areas where of high rainfall, this is a benefit because the soils there are typically acidic.

Dry areas tend to have more alkaline soil, so adding wood ash might be a problem.

If you have no garden, you can dispose of completely cold ash with your household trash.

Place it in a tightly closed bag to keep it contained.

10.0 OPERATING IN TRANSITION PERIODS (Summer)

When the outside temperature gets to be more than the temperature within the property, there is a strong possibility of the flue working in reverse. If the appliance is not lit, this will cause the draught of the flue to travel in a downward direction and the smell of smoke will be obvious in the room.

If you experience problems lighting the appliance because of the greater outside temperature, then it will be necessary to warm the flue before loading the appliance with kindling. There are various methods for this procedure. Ask your local supplier or registered chimney sweep for advice.

If the fire is lit, the heat output of the appliance is often reduced and the exhaust gases may not come out the chimney completely. This can cause them to come back into the room.

In this case,

- shake the embers more frequently,
- increase the air for combustion and
- only load a reduced quantity of fuel.

This will help to keep the chimney hot and working efficiently.

Check that all the seals of the appliance are in good order and that the connections to the chimney are also sound.

11.0 MAINTENANCE - CLEANING THE APPLIANCE

Take great care choosing the products you use to clean your appliance. A major amount of cleaning can be carried out using hot soapy water and a soft cloth. Using the wrong products will cause damage to its surfaces. Never use bleach or chlorine based products, caustic cleaners, paint solvents, biological powders, coarse abrasives or salt.

Never mix different products as they may cause a chemical reaction with each other and cause harm to either you or the appliance.

12A RECOMMENDED CLEANING PRODUCTS

For the more stubborn stains, a mildly abrasive cleaner should be used, such as 'Astonish'.

This is safe to use on enamel surfaces. Do not use Astonish on the chrome components.

For any further information, please contact your Dealer!

12B DAILY CARE

To keep the surfaces of your appliance bright and clean, a daily wipe over with a lint free cloth, soaked in hot water and a little soap is all that is needed.

To buff the cleaned surfaces, a soft, dry, lint free cloth should be used.

In order to keep your appliance in tip top condition, it is necessary to wipe up any spills or condensation streaks as soon as is safe to do so. (i.e. when the unit is cold)

This will prevent the mark burning onto the appliance and becoming a much tougher stain to remove at a later date, or causing a permanent mark. Try not to use excessive amounts of water when cleaning the appliance.

12C CLEANING THE OUTSIDE OF THE APPLIANCE:

The stove and doors of the appliance are solid cast iron and painted with a heat proof paint. These can also be cleaned with a lint free damp cloth, then wiped over with a dry cloth. Should re-painting be necessary, contact your local supplier for a can of paint.

The appliance has one main surface finish; This should be cleaned when the appliance is cool. The cooking surface (if chosen option) is cast iron and can be cleaned with a lint free damp cloth. Do not leave this surface wet as it will go rusty.

12D ASH REMOVAL:

The appliance need to have the ash removed from the ash pan and fire chamber on a regular basis. You can remove the ash from the fire chamber and ash pan by using a suitable tool (i.e a brush or specialised ash vacuum) You need to insure all air vents are clear of ash, there is no ash build up on baffles or firebricks and that excess build up of ash is removed from all parts of the stove. This needs to be done as and when necessary to maintain free movement of air inside the stove. The efficient operation of your appliance is dependant on its correct operation and maintenance. Leaving soot to accumulate inside the areas mentioned above, will drastically reduce the output of the appliance and prevent it from doing what it is designed to.

12E GLASS CLEANING:

There are various glass cleaners you can buy at stove shops that are specially designed to remove hydrocarbon (soot) and fly ash (mineral) deposits from the glass. Follow the manufacturers instructions. Typically, just spray a small amount of cleaner on the glass and use a paper towel or rag to wipe it clean.

If you only burn logs in your appliance, then you can dip a damp cloth in the ash and use this to scrub the glass clean.

12F FLUE MAINTAINENCE:

If your appliance is installed into an existing chimney, you will need to clean the chimney as well as the flue pipe at least twice a year. To do this you will need the appropriate sized chimney brush and rods. Call a certified chimney sweep (National Association of Chimney Sweeps) or other qualified professional to clean the flue system. These professionals have the equipment and the experience to do a thorough job. The sweep will advise you as to the intervals that you should have your flue swept. We would recommend that you have it swept at least twice a year, but you may need to sweep it more.

Get them to inspect the condition of all the associated chimney items at the same time.

Be sure to check the pipe at least once every six months to determine if it has corroded.

12G ROPE SEALS:

For the appliance to operate correctly, it is important that all the seals; where fitted; are in good condition and are sealing correctly. They should be replaced if they are showing excessive signs of fraying and are not making a good seal. They are glued into position using a high temperature, flexible, silicone sealant

12H AIR CONTROLS:

Ensure that all the air controls operate smoothly and are free from ash or other foreign bodies.

13.0 INSTALLATION OF THE APPLIANCE

13.A FLUE REQUIREMENTS

The chimney is possibly the most important part to your installation; great care should be given to its design. An older chimney, in need of repair, is a fire hazard in any installation.

The chimney must be thoroughly swept, checked for soundness and suitability, before any connection is made to the appliance. This must be carried out by a qualified person. A "Declaration of Completion" certificate must be obtained by the end user for the installation, failure to obtain this document may void the products warranty.

- This appliance must be installed into a '**Class 1 Chimney**'. If there is no existing chimney, then an approved solid fuel, factory built, prefabricated block type or a twin walled, stainless steel flue can be used. Get advice from a qualified chimney engineer.
- The flue diameter of this appliance must be a minimum of 150mm.
- In order for the appliance to perform satisfactorily, the chimney height must not be less than 4 meters measured vertically from the stove outlet to the top of the chimney.
- Adequate access for sweeping the flue, such as a soot door, must be provided. This will dramatically improve the ease of cleaning and sweeping of the flue.
- Flue pipe should be fitted inside the flue pipe collar (spigot) to prevent creosote and condensates from running down onto the top of the appliance.
- All flue pipe has to be suitable for solid fuel and fitted in accordance with building regulations, whilst complying with current legislation and manufacturers' instructions.
- If excessive draw is present, then a suitable draught stabilizer should be fitted. This must be fitted in the same room as the appliance is located.
- If the chimney suffers from down draught, then a special 'anti-downdraught' cowl will need to be fitted. In exposed windy locations, a 'stabilizing' cowl may need to be fitted. The minimum cowl requirement that we recommend, is a rain cowl with a bird guard.
- No flue sharing with other appliances is allowed.
- If a rear flue is able to be fitted, the horizontal length must be no longer than 150mm.

13B LINING THE FLUE

An insulated chimney is the most efficient and safe way to burn wood.

An insulated chimney helps prevent the formation of tar deposits.

A standard chimney will gradually get saturated in tar, this is a fire hazard.

Tar stains may appear on the surface of the chimney breast inside the property.

14.0 SITING THE APPLIANCE

This appliance must not be fitted into a location where it will be impossible to service.

The location must comply with the requirements laid down in the building regulations.

14A HEARTH REQUIREMENTS

It is essential that the hearth / base on which the appliance will stand is strong enough to support the weight of the appliance and the chimney / flue. If not, independently support.

It must be level and made of a suitably robust, non combustible material.

The positioning of the appliance and dimensions of the hearth must comply with current building regulations. A constructional hearth needs to be at least 125mm thick.

It must extend at least 150mm each side of the appliance.

It must project at least 300mm in front of the appliance.

A change in level of at least 12mm is advised to mark the perimeter.

There should be a 50mm air space under the constructional hearth if combustible material is present OR the combustible material should be 250mm below the top of the hearth.

The superimposed, decorative hearth is laid on top of the constructional hearth.

STOVE CLEARANCES TO FLAMMABLE MATERIALS

- The minimum distance from any flammable object, or one that is sensitive to heat, (furniture, wood, fabrics. etc.) and from materials with flammable structure, must be 20 cm's to the rear and on both sides.
- In front of the stove there must not be any flammable object or building material, sensitive to heat within 100 cm's.
- Above the stove, there must not be any flammable items within 700mm.
- Never deposit / store any flammable materials near the stove.

STOVE CLEARANCES TO NON - FLAMMABLE MATERIALS

- The minimum distance from any NON FLAMMABLE object, or one that is NOT sensitive to heat, (stone brick slate etc.) and from materials with non flammable structure, must be 100 mm's to the rear and on both sides.

PLEASE REFER TO BUILDING REGULATIONS "WALLS ADJACENT TO HEARTHS" for further information.

Where the hearth abuts a wall and the appliance is more than 50mm but not more than 300mm away:

- The thickness of the wall needs to be at least 75mm.
- The height of the wall needs to be at least 1.2M above the hearth.

15.0 ADDITIONAL VENTILATION

There must be sufficient free air for combustion into the room where the appliance is installed.

Permanent openings or vents must not be covered. Vents needs to be positioned carefully, they must be protected from direct wind conditions. A baffle that has been specially designed to fit over the vent will protect it from the effects of wind, but must not restrict the total vent area and must be secured in a way that prevents its movement. Regular inspection of any vents is critical to ensure that the vent has not become restricted.

The appliance may require up to 20 m³/hour of combustion air. The natural recirculation of air must be guaranteed by having permanent ventilation to the outside.

An extractor fan, cooker hood or similar product, installed in the same room, or in a room nearby; that sucks air out (aspirating); may negatively affect the functions of your cooker.

If the room contains more than one appliance; of the type that requires combustible air; a calculation will need to be made to re-calculate the permanent air vent requirement.

16.0 Fitting the Spigot and Blanking Plate

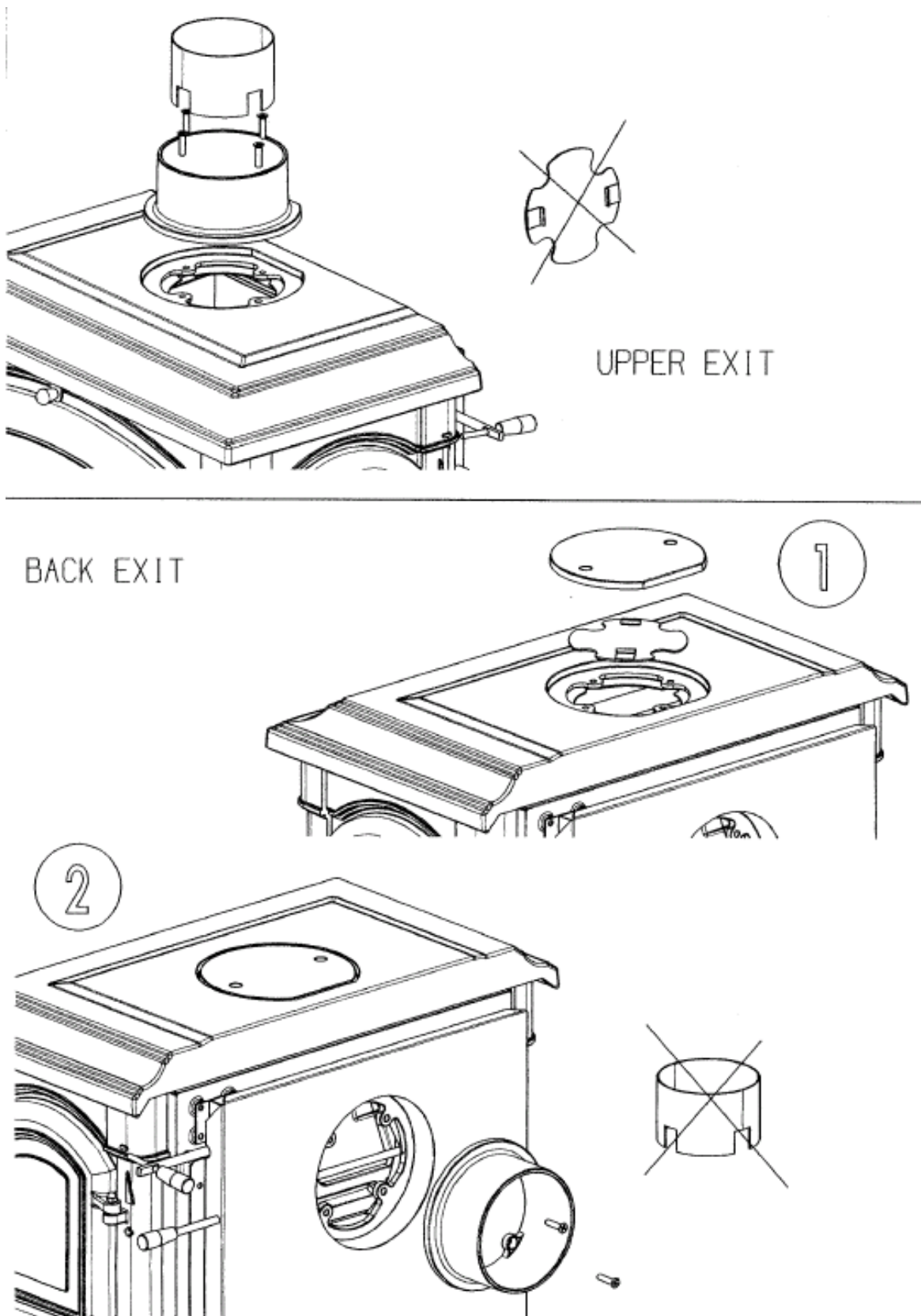

ANNUAL SERVICE RECORD

INSTALLATION DATE OF APPLIANCE: _____

1ST YEAR SERVICE completion date: _____

SERVICE ENGINEER: _____ . . REG. No. _____

COMPANY NAME: _____ .

COMPANY ADDRESS: _____ .

POSTCODE: _____

CONTACT NUMBER _____

2ND YEAR SERVICE completion date: _____

SERVICE ENGINEER: _____ . . REG. No. _____

COMPANY NAME: _____ .

COMPANY ADDRESS: _____ .

POSTCODE: _____

3RD YEAR SERVICE completion date: _____

SERVICE ENGINEER: _____ . . REG. No. _____

COMPANY NAME: _____ .

COMPANY ADDRESS: _____ .

POSTCODE: _____

4TH YEAR SERVICE completion date: _____

SERVICE ENGINEER: _____ . . REG. No. _____

COMPANY NAME: _____ .

COMPANY ADDRESS: _____ .

POSTCODE: _____

5TH YEAR SERVICE completion date: _____

SERVICE ENGINEER: _____ . . REG. No. _____

COMPANY NAME: _____ .

COMPANY ADDRESS: _____ .

POSTCODE: _____

6TH YEAR SERVICE completion date: _____

SERVICE ENGINEER: _____ . . REG. No. _____

COMPANY NAME: _____ .

COMPANY ADDRESS: _____ .

POSTCODE: _____

LIMITED WARRANTY

This appliance must be installed and commissioned by a fully qualified, registered engineer. A "Declaration of completion Certificate" must be obtained for the installation and retained by the end user. Failure to comply with these requirements may void your warranty. You, as the end user, have a contract by law with the supplier / dealer from whom you purchased the product. That dealer then has the same contract with the manufacturer or wholesaler and these have a contract with their suppliers.

ALL CLAIMS MUST FOLLOW THIS PROCEDURE.

Thank you for choosing a Product from **Broseley Fires Ltd**. This warranty gives you specific legal rights. The statutory rights of the consumer are not affected by the warranty, or the consumers' rights against the dealer arising from their sales / purchase contract.

The manufacturers' warranty:

Your Product will be free from defective parts, material, and workmanship at the time of its original purchase for a period of one (1) year. This Warranty will become active as of one month from the date of delivery.

This warranty does not cover any failure of the unit due to normal wear and tear, misuse, abuse, accident, illegal modification, illegal installation or repair, damage resulting from improper use or failure to maintain the product. Variations in color and texture are a natural characteristic of cast iron products. Colour changes may result from exposure to light and other elements which are a part of the aging process. These material variations and changes are not covered by this warranty.

If during the warranty period, this Product fails to operate under normal use and service, due to defects in material and / or workmanship, Broseley Fires will either repair or replace the product. The repaired or replaced product shall be warranted for the remaining period of the original warranty + the time taken to days from the date of repair, whichever is longer.

Repair or replacement may involve the use of functionally equivalent reconditioned units. Replaced parts or components will become the property of Broseley Fires.

Should you wish to claim under the warranty, please contact the supplier / dealer from whom you purchased the appliance. Do not claim directly to Broseley Fires, as they are unable to process any direct claim from an end user.

Product design and any specifications are subject to change without notice. This is due to our continuous product development and improvement. The buyer will not be entitled to request free upgrades to the new design or compensation for previously purchased products or any products on order.

- This Warranty covers all Broseley Fires costs within the Warranty period.

If the appliance remains uninstalled for a period greater than six months from date of delivery the Warranty will become active six months from the date of original invoice to the distributor.

IN NO EVENT SHALL BROSELEY FIRES BE LIABLE FOR INCIDENTAL OR CONCEQUENTIAL DAMAGES OF ANY NATURE WHATSOEVER, INCLUDING BUT NOT LIMITED TO LOST PROFITS OR COMMERCIAL LOSS, TO THE FULL EXTENT THOSE DAMAGES CAN BE DISCLAIMED BY LAW. (if applicable)

NON - COVERAGE OF THE GUARANTEE

The consumable items within the product are not covered by the warranty, nor is the glass
If the end-user's claim should not be covered by this guarantee, the end-user shall be liable for costs incurred by Broseley Fires such as callout and inspection costs for examination of the product, transportation costs of the product as well as any other relevant costs. If, after having been informed about the non-coverage of the guarantee, the end-user wants to have the repairs done, the end-user shall additionally pay for any spare parts used and for the labour and transportation costs incurred. If repairs are carried out under this guarantee, the remaining guarantee period for the product shall be extended by the period of time that has elapsed since the complaint was officially logged with Broseley Fires until the repairs have been completed

A COPY OF OUR FULL TERMS AND CONDITIONS IS AVAILABLE ON REQUEST.

** End-user means the natural or legal person who owns the product and who has not acquired it with a view to reselling or installing it in the course of business